

DOOR  
HANDLE  
DESIGN







THIS CATALOG IS DEDICATED TO  
PEOPLE WHO DEEPLY BELIEVE IN THE  
IMPORTANCE OF DOING THINGS  
RIGHT. WHERE DESIGN, FUNCTION AND  
SAFETY COME TOGETHER TO CREATE  
PERFECT PIECES.

*ESTE CATÁLOGO ESTÁ DEDICADO  
A TODOS AQUELLOS QUE CREEN  
PROFUNDAMENTE EN LA IMPORTANCIA  
DE HACER BIEN LAS COSAS. DÓNDE EL  
DISEÑO, LA FUNCIÓN Y LA SEGURIDAD  
SE UNEN PARA CREAR PIEZAS  
PERFECTAS.*

groëil

## OUR SECRET NUESTRO SECRETO



We have been producing handles since 1998, following excellence criteria in all our production phases with creative designs defying time. We are a team of young and proactive professionals that with positive and clear vision, and coherence to present times are eager to thrive looking to the future.

Only this way we manage to remind our customers that handles are not ordinary objects, but a harmonic way in which our hands connect with our homes..

*Desde 1998 producimos manillas siguiendo criterios de excelencia en todas las fases de producción utilizando la creatividad, produciendo diseños que desafían al tiempo. Ideas claras, visión positiva, irrenunciable afán de superación, es lo que atesora nuestro equipo de profesionales jóvenes y activos, coherentes con la realidad pero siempre mirando al futuro.*

*Solo con esta sinergia conseguimos hacer recordar que la manilla no es un objeto banal sino la forma armónica con la que conecta nuestra mano con el hogar.*



Daniel & Carlos Torregrosa  
CEOs



DESIGN  
*DISEÑO*





Basing ourselves on our values and principles, we manage to meet the market's needs with coherence and provide a unique and inspiring experience through each of our designs.

*Basándonos en nuestros valores y principios, logramos ser coherentes ante las necesidades del mercado y poder ofrecer una experiencia única e inspiradora a través de cada uno de nuestros diseños.*

## RAW MATERIAL *MATERIA PRIMA*



### **Pure brass**

Brass without plumb for fluid transport suitable for human consumption, controlled and certified.

### **Latón puro**

*Latón sin plomo para fluidos aptos al consumo humano, controlado y certificado.*







°celsius

8000



pressure in tons

975

## STAMPING ESTAMPADO



pieces per hour

# 150



### **Forging**

Exhaustive temperature control, maximum stamping power and high speed of production.

### **Forjado**

Control exhaustivo de temperatura, máxima potencia de estampado y alta velocidad de producción.



### **Numerical control**

With precision, essential to secure a quality standard in every single piece.

### **Control numérico**

*De precisión, imprescindible para asegurar excelencia en todas y cada una de las piezas.*



**MACHINING**  
**MECANIZADO**

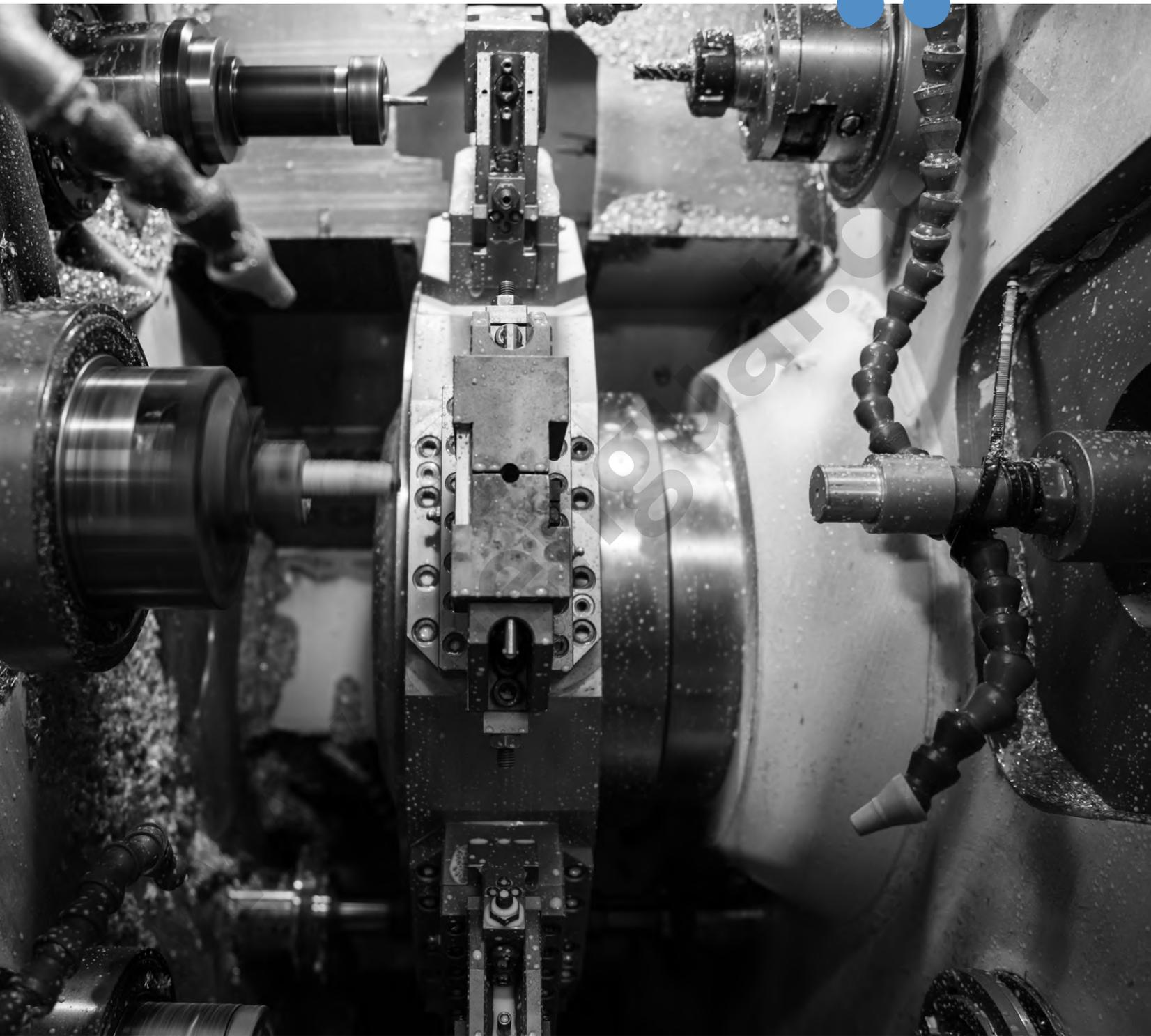

# GRINDING ESMERILADO

## Automated robot

This important process secures a rigorous quality standard from the first to the very last piece by preparing the brass's surface for the following steps.

## Robot automatizado

Este importante proceso asegura un riguroso estándar de calidad de la primera a la última pieza, preparando la superficie de latón para los sucesivos pasos.

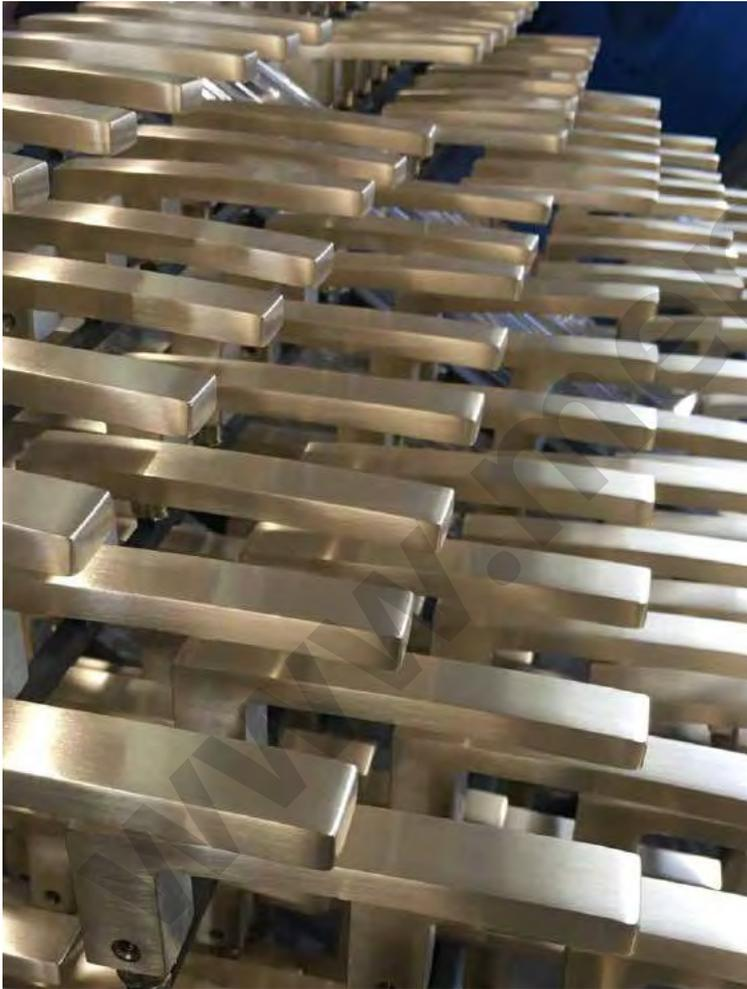









## MANUAL GRINDING ESMERILADO MANUAL

### **Expert's hands**

When our robots do not manage to attain the requirements of an optimal grinding, our experienced craftsmen come into play to bring their expertise and manually adjust it.

### **Manos expertas**

*Cuando los robots no llegan a cumplir las exigencias de un buen esmerilado, es cuando entran en juego las manos de nuestros expertos artesanos que saben donde hay que ajustar.*

**POLISHED**  
**PULIDO**

**Manual control**

Each of our models is meticulously and manually controlled to provide a flawless product.

**Control manual**

*Cada uno de nuestros modelos es controlado manual y minuciosamente para ofrecer un producto impecable.*





## **SATIN** *SATINADO*

### **Matt**

Always on a perfectly polished surface to achieve the maximum quality.

### **Mate**

*Siempre sobre una superficie perfectamente pulida para obtener la máxima calidad.*





### Chrome III

It's a trivalent CHROME III process fully respectful with the environment and highly resistant.

### Cromo III

Es un proceso con cromo trivalente CROMO III totalmente respetuoso con el medioambiente y de altísima resistencia.



## GALVANIC CHROME III GALVÁNICA



### **Chrome III HIGH THICKNESS**

Chrome with high thickness for satin surfaces. It increases the resistance to corrosion and daily use.

### **Cromo III ALTO ESPESOR**

*Cromo de alto espesor para superficies satinadas. Aumenta la resistencia frente a la corrosión y el uso cotidiano.*

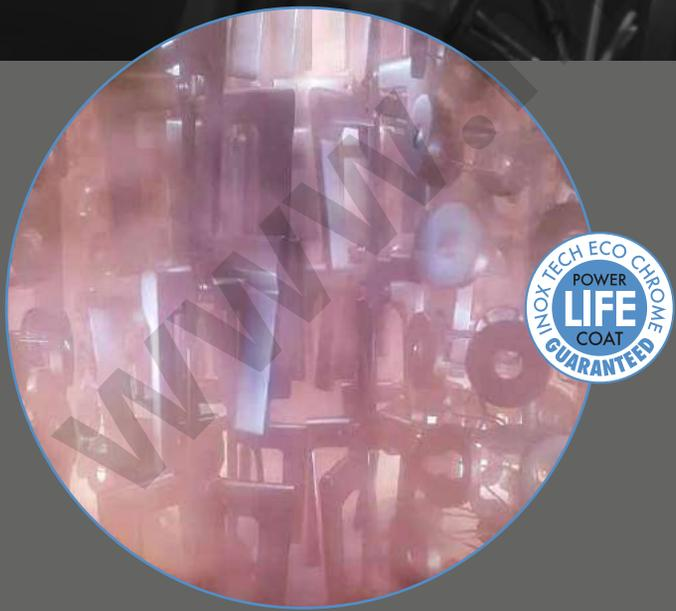

### **PowerCoat**

It's a technical process through titanium ionised plasma gas covering the handle's surface providing a remarkable resistance. Besides, it's a hypoallergenic process with Zero environmental impact. For technological reasons, occasional tonality tolerances in this process may occur.

### **PowerCoat**

*Es un proceso técnico mediante plasma de gas ionizado de titanio que recubre la superficie de la manilla dándole una resistencia asombrosa. Además de ser un proceso hipoalergénico y de Zero impacto ambiental. Por motivos tecnológicos, una ocasional tolerancia de tonalidad en este proceso debe de considerarse normal.*



*powercoat*





## VARNISHING BARNIZADO

### Varnishing

By using the latest generation's water varnishes we manage to enhance the beauty of our materials following the strictest sustainability standards.

### Barnices

Utilizando barnices al agua de última generación conseguimos realzar la belleza de los materiales siguiendo las más estrictas normas de sostenibilidad.

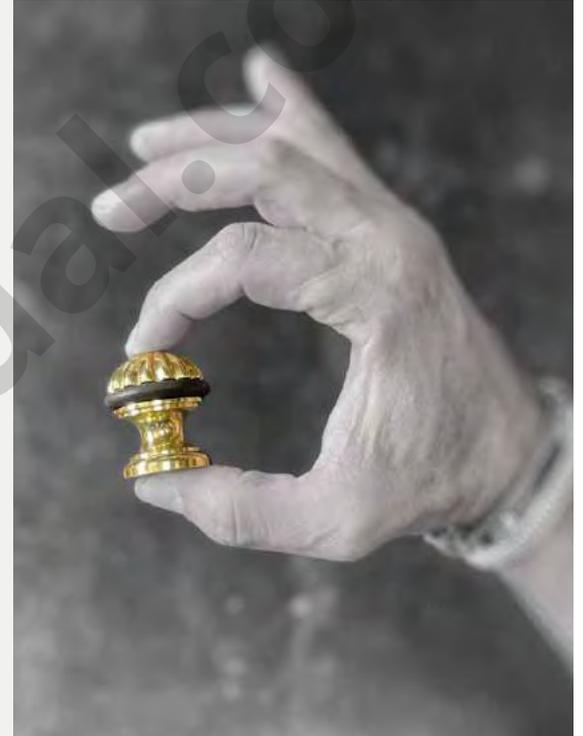



**PAINTED  
PINTADO**

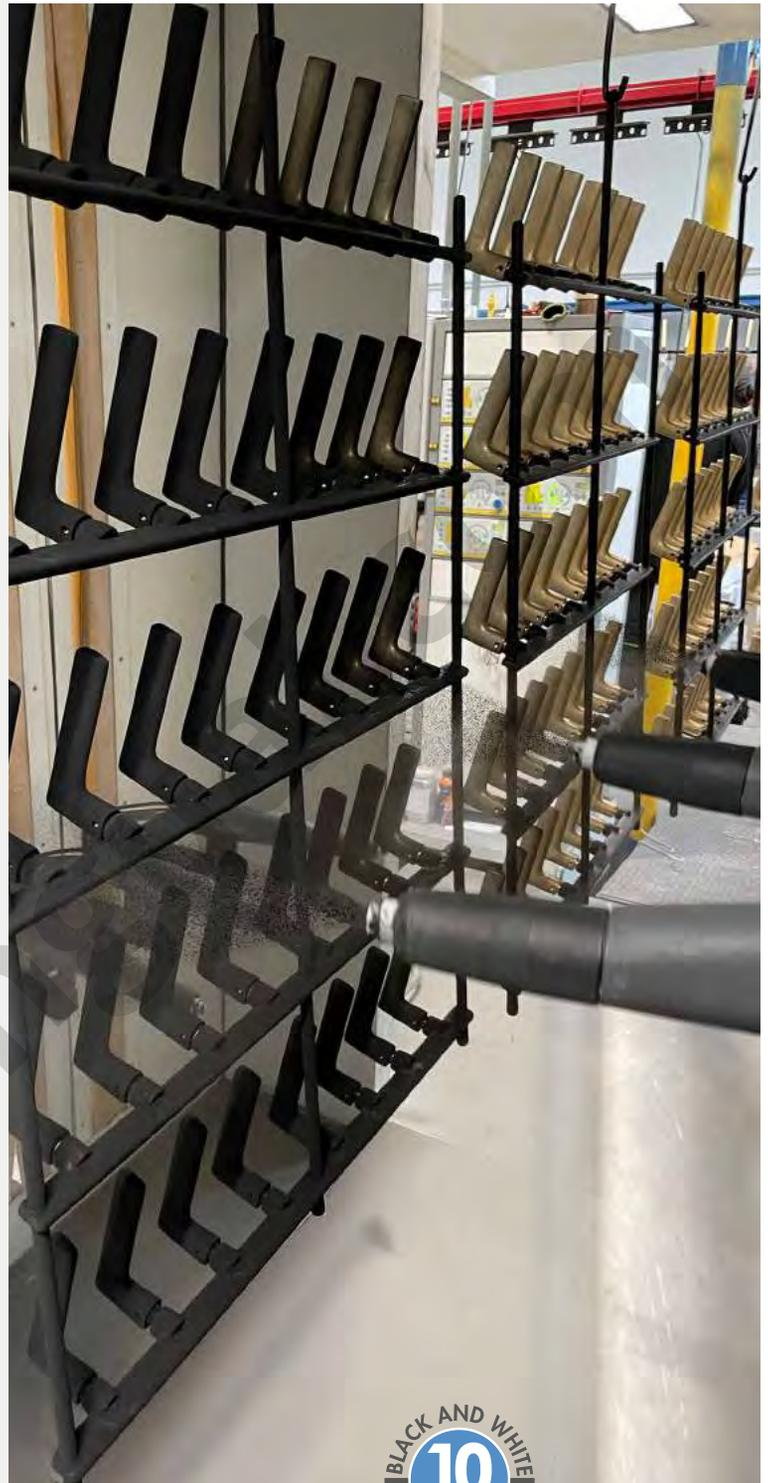

**Painted**

EPOXY lacquered is highly adherent and resistant to environmental agents (ISO 9227) and to UV radiation (EN ISO 13474-2 2014).

**Pintado**

Lacado EPOXY de alta adherencia y elevada resistencia frente a los agentes ambientales (ISO 9227) y a la radiación ultravioleta (EN ISO 13474-2 2014).



TUNING  
PERSONALIZACIÓN



**Only for You**

Custom manufacturing process  
and personalized on-demand.

**Solo para tí**

Fabricación a medida y  
personalizada bajo demanda.



## STORAGE ALMACÉN

### **Just in time**

Immediate availability of all our products displayed on the catalogue in order to meet the market's delivery needs.

### **Justo a tiempo**

Disposición inmediata de todos nuestros productos catalogados con el fin de poder atender las exigencias del mercado.



# PACKAGING ENVASE



### Sustainable future

Scrupulous sensitivity with the environment. Recycled materials and 100% recyclable.

### Futuro sostenible

Escrupulosa sensibilidad con el entorno. Materiales reciclados y 100% reciclables.



# SHIPMENT ENVÍO

## Across the world

We are partnered with the most prestigious and reputable transport agencies in the world.

## A todo el mundo

Contamos con las agencias de transportes más prestigiosas y serias del mundo.





---

We carefully comply with environmental legislation and regulations supporting an economically sustainable management model.



*Cumplimos cuidadosamente con la legislación y normativa medio ambiental apostando por un modelo de gestión basado en la economía sostenible.*

---



ECOLOGY  
ECOLOGÍA

[www.genpubli.com](http://www.genpubli.com)  
**ZERO**

### Barcelona

The peculiar cantilever of the building that recreates a of large door that opens to the Barceloneta neighbourhood, fitting perfectly with the LOG.GIC door handle.

### Barcelona

*El característico voladizo del edificio que recrea una especie de gran puerta que permite abrirse al barrio de la Barceloneta, encajando perfectamente con la manilla LOG.GIC.*



### Qatar

The NINA door handle is present at the construction of the Al Rayyan Stadium in Qatar, a monumental work that has not left anyone indifferent.

### Qatar

*La manilla NINA presente en la construcción del Al Rayyan Stadium, una obra monumental que no ha dejado indiferente a nadie.*

### Sevilla

Built to accommodate international dignitaries during the 1929 exhibition, Hotel Alfonso XIII, A Luxury Collection Hotel where the handle MARÍA was chosen for the refurbishment.

### Sevilla

*Construido para alojar a los dignatarios internacionales durante la exposición de 1929, el Hotel Alfonso XIII, a Luxury Collection Hotel cuenta en su renovación con la manilla MARÍA.*





## PROJECTS PROYECTOS

### Paris

The BACI handle's presence in the new offices of the prestigious Gide Law Firm.

### París

La presencia de la manilla BACI en las nuevas oficinas del prestigioso Bufete de Abogados Gide.

### Mallorca

The HÉLICE door handle is found at the Park Hyatt, a luxury hotel complex that reflects the lifestyle of a traditional Mallorcan mountain village.

### Mallorca

La manilla HÉLICE en el Park Hyatt, complejo hotelero de lujo que refleja el estilo de vida de un pueblo tradicional de montaña mallorquín.

### Alicante

The Palacio Salvetti Suites and the handle SPECIAL open their doors with views to the garden, private pool and every comfort very close to the Levante beaches.

### Alicante

El Palacio Salvetti Suites y la manilla SPECIAL abren sus puertas con vistas al jardín, piscina privada y todo el confort muy cerca de las playas de levante.



## PROJECTS PROYECTOS



### Paris

The SPECIAL door handle has been the protagonist in the refurbishment of the Howard Orly Hotel.

### París

La manilla SPECIAL ha sido la protagonista en la actualización del Hotel Howard Orly.

### Cannes

The new Artdéco handle fits perfectly in the JW Marriott Hotel room update.

### Cannes

La nueva manilla Artdéco encaja perfectamente en la actualización de las habitaciones del Hotel JW Marriott.

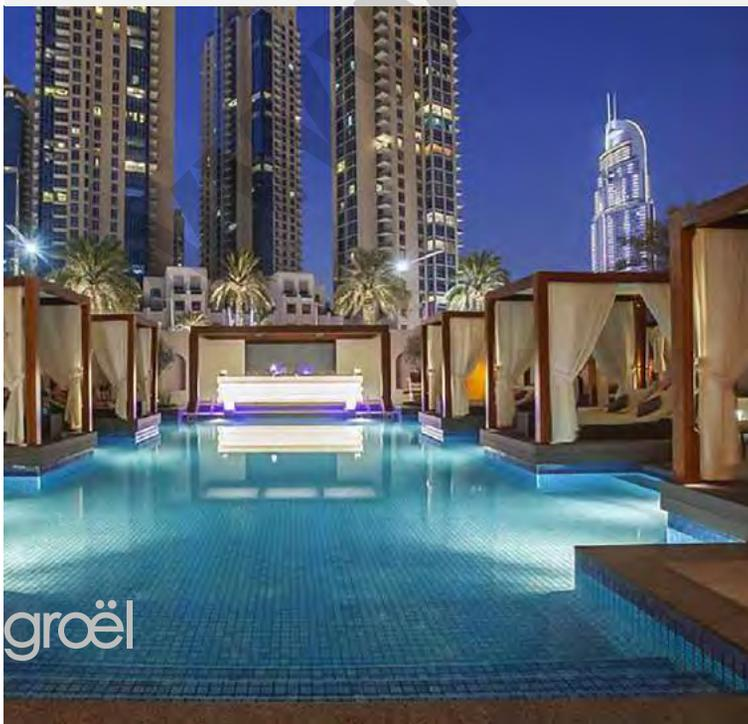

### Dubai

Our flagship, the ÁNGOLO handle is the exclusive ambassador at the Vida Appart Hotel.

### Dubai

Nuestro buque insignia, la manilla ÁNGOLO como embajador exclusivo en el Vida Appart Hotel.



● ● ETC...  
ETC...

- Double Three by Hilton, A Coruña.
- Sea One, Marseilles.
- Hotel Mezquita Center, Córdoba.
- Ratxo Hotel, Mallorca.
- Symbiose BAGNEUX, Paris.





# FINISHES ACABADOS



N OB



G NS



V LP



PW PWLP



V LS



V LS/LP



V BO



PW PWGT



V FU



V AQ



V HI



G CR



V MR

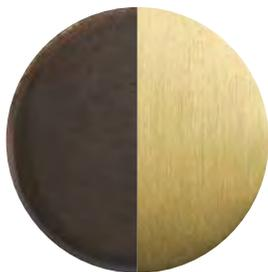

V MR/LS



C WTM

www.metalgal.com



PW PWLS LIFE COAT



PW PWIX LIFE COAT



PW PWNB LIFE COAT



PW PWCO LIFE COAT



G CS LIFE COAT 15



G CR/CS LIFE COAT 15



C BK 10



C WT 10

# POWERCOAT

## PowerCoat



- PWLP POLISHED BRASS  
*Latón Pulido*
- PWLS SATIN BRASS  
*Latón Satinado*
- PWIX INOX TECH  
*Inox Tech*
- PWGT GRAPHITE  
*Grafito*
- PWNB POLISHED NICKEL  
*Níquel Brillo*
- PWCO COOPER  
*Cobre*

# PAINTED

## Pintado



- WT BRIGHT WHITE  
*Blanco Brillo*
- BK BLACK  
*Negro*
- WTM MAT WHITE  
*Blanco*

# GALVANIC

## Galvánico



- CR POLISHED CHROME  
*Cromo Brillo*
- NS SATIN NICKEL  
*Níquel Satinado*
- CS SATIN CHROME  
*Cromo Satinado*
- CR CS POLISHED/SATIN CHROME  
*Cromo Brillo/Satinado*

# VARNISHING

## Barnices



- LP POLISHED BRASS  
*Latón Pulido*
- LS SATIN BRASS  
*Latón Satinado*
- LS LP SATIN BRASS/POLISHED  
*Satinado/Latón Pulido*
- BO MAT BRONZE  
*Bronce Mate*
- FU POLISHED BRONZE  
*Bronce Brillo*
- AQ ANTIQUE BRASS  
*Envejecido*
- HI IRON  
*Efecto Hierro*
- MR BROWN  
*Marrón*
- MR LS BROWN/SATIN BRASS  
*Marrón/Latón Satinado*

# NATURAL

## Natural



- OB OLD BRASS  
*Bronce Envejecido*

Round Door Handles  
Manillas Redondas



**117 LOG.GIC**  
p. 41



**133 HÉLICE**  
p. 45



**134 TOUCH**  
p. 49



**135 SENS.SO**  
p. 53



**137 PLANO**  
p. 57



**147 FILA**  
p. 59



**157 SWIM**  
p. 63



**204 SLIM**  
p. 65



**214 TENDENZA**  
p. 67



**218 SOKOL**  
p. 73



**219 VOLLA 219**  
p. 75



**232 PIN**  
p. 77



**233 THREE**  
p. 81



**237 FLOW**  
p. 83



**247 SPECIAL**  
p. 85



**255 SASHA**  
p. 89



**256 IBIZA**  
p. 91



**804 IDEA**  
p. 95



**806 FEY**  
p. 97



**807 SOFT**  
p. 99



**811 NINA**  
p. 101



**812 ROBY**  
p. 103



**813 JET**  
p. 107



**814 BACI**  
p. 109



**815 DADÁ**  
p. 115



**816 IPNOS**  
p. 117



**817 ÁNGOLO**  
p. 119



**117 LOG.GIC**  
p. 125



**134 TOUCH**  
p. 127



**135 SENS.SO**  
p. 129



**137 PLANO**  
p. 131



**147 FILA**  
p. 135



**157 SWIM**  
p. 137



**201 NADIA**  
p. 139



**204 SLIM**  
p. 141



**213 STRIP**  
p. 143



**219 VOLLA**  
p. 145



**227 QUADRA**  
p. 147



**232 PIN**  
p. 149



**233 THREE**  
p. 151



**237 FLOW**  
p. 155



**247 SPECIAL**  
p. 159



**814 BACI**  
p. 163



**815 DADÁ**  
p. 167



**817 ÁNGOLO**  
p. 169

Atelier  
Atelier



**510 TROMBETTA**  
p. 175



**520 MANEGA**  
p. 177



**528 OTTO**  
p. 179



**533 PALLINE**  
p. 183



**540 VASILISA**  
p. 185



**809 KILTO**  
p. 215



**550M ARTDÉCO**  
p. 229



**327 DADO**  
p. 247



**550 ARTDÉCO**  
p. 189

Pull Handles  
Manillones



**560M NONNA**  
p. 231



**335 BIG**  
p. 249



**555 NEW YORK**  
p. 191



**110M BELLA**  
p. 218



**570M MALIKA**  
p. 233



**357 WIDE**  
p. 250



**560 NONNA**  
p. 193



**127M QUADRO**  
p. 219



**801M TECNO**  
p. 235



**318 DADO**  
p. 251



**570 MALIKA**  
p. 195



**137M PLANO**  
p. 220



**805M NUOVO**  
p. 236



**319 CUBE**  
p. 251



**580 ELISABETH**  
p. 197



**217M SKETCH**  
p. 221



**809M KILTO**  
p. 237

Accessories  
Accesorios



**590 CHÉRIE**  
p. 199



**235M TORSO**  
p. 222



**MARÍA 810M**  
p. 238



**ESCUTCHEON**  
p. 254



**595 DOVE**  
p. 201



**256M IBIZA**  
p. 223



**817M ÁNGOLO**  
p. 239



**WC SET**  
p. 256



**616 ESPUCH**  
p. 203



**510M TROMBETTA**  
p. 224



**827M LOG.GIC**  
p. 240



**PLATES**  
p. 258

Rustic Door Handles  
Manillas Rústicas



**520M MANEGA**  
p. 225

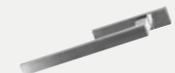

**400 LIFTER**  
p. 241



**SLIDING DOOR KIT**  
p. 259



**108 BELLA**  
p. 207



**528M OTTO**  
p. 226



Door Knobs - Stoppers  
Pomos - Topes

Technical Information  
Información Técnica



**803 MARÍA**  
p. 209



**533M PALLINE**  
p. 227



**316 DÉCO**  
p. 245



**TECHICAL DATA**  
p. 261



**808 DEV**  
p. 213



**540M VASILISA**  
p. 228



**317 CUADRO**  
p. 246



**ASSEMBLING MAINTENANCE**  
p. 362







**ROUND DOOR HANDLES**  
*MANILLAS REDONDAS*

[www.meripostal.com](http://www.meripostal.com)

**Gentle, contemporary, nevertheless stylish**

*The LOG.GIC model presents an ingenious style. A handle with subtly rounded profiles, with which we broke the barriers of time.*

**Gentil, contemporánea no exenta de estilo**

*El modelo LOG.GIC presenta un estilo ingenioso. Es una manilla de perfiles sutilmente redondeados, con la que rompimos la barrera del tiempo.*



**LOG.GIC 117**

# LOG.GIC 117



Simply  
elegant.

*Simplemente  
elegante.*





[www.menggual.com](http://www.menggual.com)







### **Equally ergonomic and beautiful**

The meticulous combination of planes and curves in the most scrupulous way results in a single purpose, design excellence. The gentle curvature of this handle allows the hand to rest comfortably on it without losing any of its splendor.

### **Ergonómica y bella a partes iguales**

*La minuciosa combinación de planos y curvas de la forma más escrupulosa da como resultado un propósito único, la excelencia del diseño. La suave curvatura de esta manilla hace que la mano descanse cómodamente en ella sin perder lo más mínimo su esplendor.*



www.mengsual.com

● ● TOUCH 134



www.hmcgroup.it



**Straight lines denoting strength and emphasis**

Robust, firm and compact in design, enhanced by chrome finishes, this handle is a perfect model for discrete environments.

**Líneas rectas que denotan fuerza y empaque**

Robusta, firme y de diseño compacto, realizado por sus acabados cromados haciendo de esta manilla un modelo perfecto para ambientes sobrios.

# TOUCH 134



\*Q 127 | TD 268



SENS.SO 135







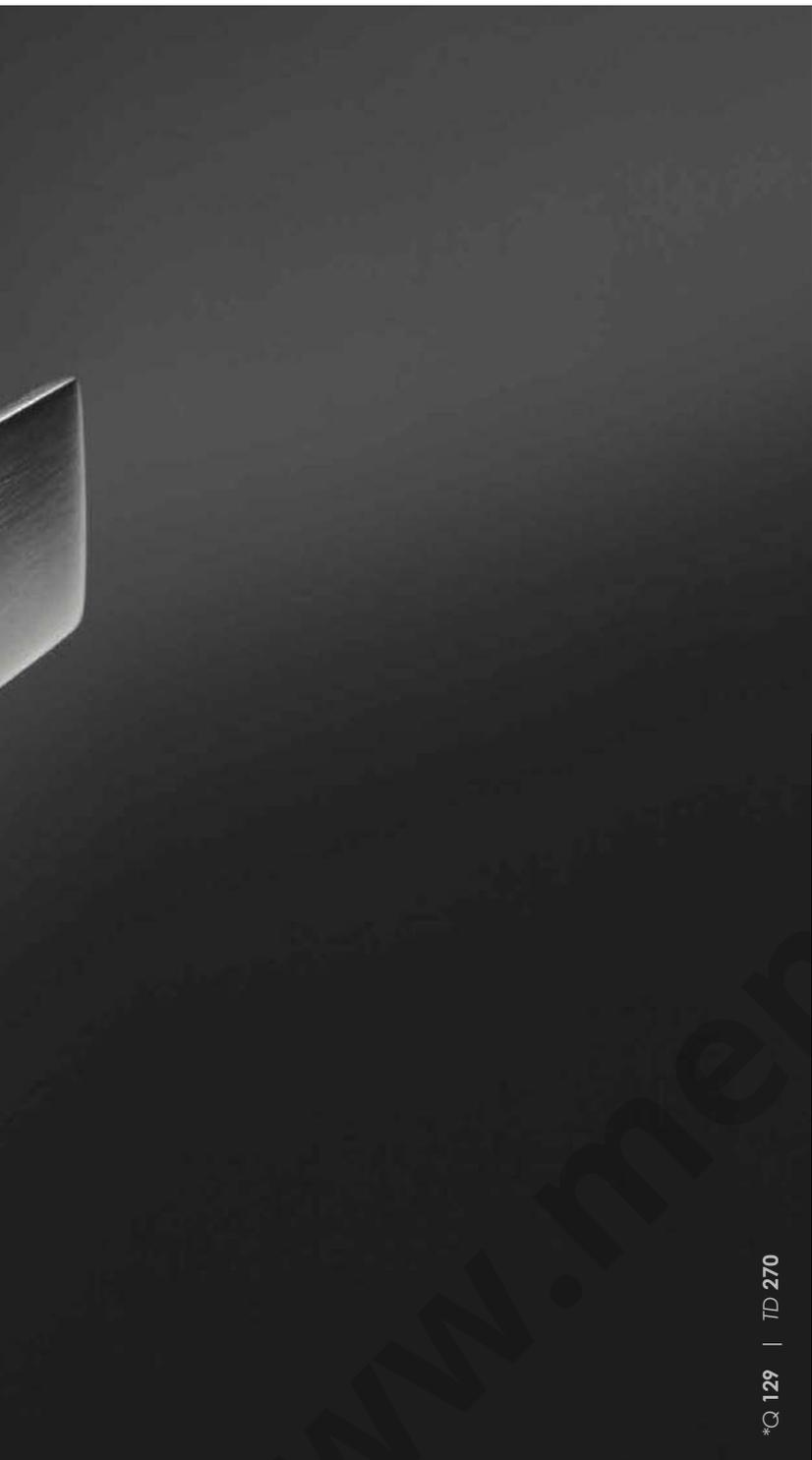

\*Q 129 | TD 270



## SENS.SO 135



### **Majestic and tenacious, a double sensation**

Handles are objects with a life of their own. They imbue your home with their own personality and character. While remaining elegant, its functionally refined profile blends into the atmosphere of the most demanding household.

### **Majestuosa y tenaz, una doble sensación**

Las manillas son objetos con vida propia. Impregnan tu hogar de personalidad y carácter propio. Sin dejar de ser elegante, su funcionalidad de perfil depurado, se funde en el ambiente del hogar más exigente.

**Minimalism, serenity  
and practicality**

The intersection between a cube and a plane in space results in a simple three-dimensionally structured handle that will not go unnoticed. Extreme simplicity.

**Minimalismo, serenidad  
y practicalidad**

*La intersección entre un cubo y un plano en el espacio da como resultado una manilla sencilla con estructura tridimensional que no pasará desapercibida. Simplicidad extrema.*

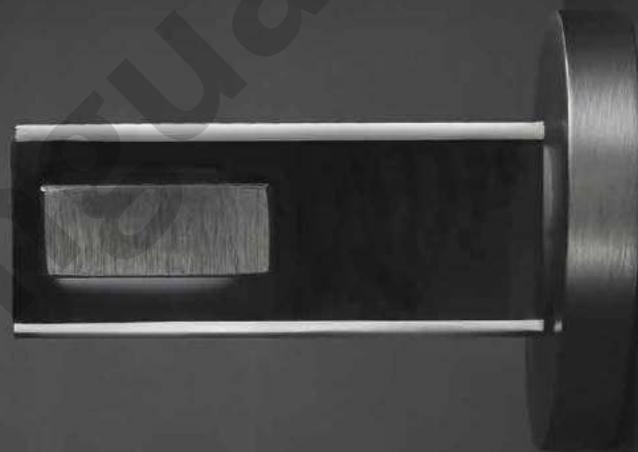



[www.mengual.com](http://www.mengual.com)



FILA 147



\*Q 135 | TD 274

## FILA 147

### **Ingeniously culminating**

Owing to its vast range of finishes, this model suits any type of decoration and stands out for its simplicity and purity of lines. Popular for its originality in design.

### **Ingeniosamente culminante**

Para cualquier tipo de decoración con su vasta gama de acabados, destaca por su sencillez y pureza de líneas. Popular por su originalidad en diseño. Una elección acertada.







**The warmth of a charming minimalism**

A wink to every lover of delicate curves on planes. A model with character, but simple and natural.

**La calidez de un minimalismo encantador**

*Un guiño para todos los amantes de delicadas curvas del plano. Un modelo con carácter, pero simple y natural.*



● ● SWIM 157



**A slender and discrete identity**

Subtle in appearance with perfect proportions, rounded angles and pleasant to the touch. A balanced design. Simplicity brought to the extreme.

**Una identidad fina y discreta**

*De apariencia sutil con proporciones perfectas, ángulos redondeados y agradable al tacto. Un diseño equilibrado. La simplicidad llevada al extremo.*



\*Q 141 | TD 280

SLIM 204



[www.menggual.com](http://www.menggual.com)

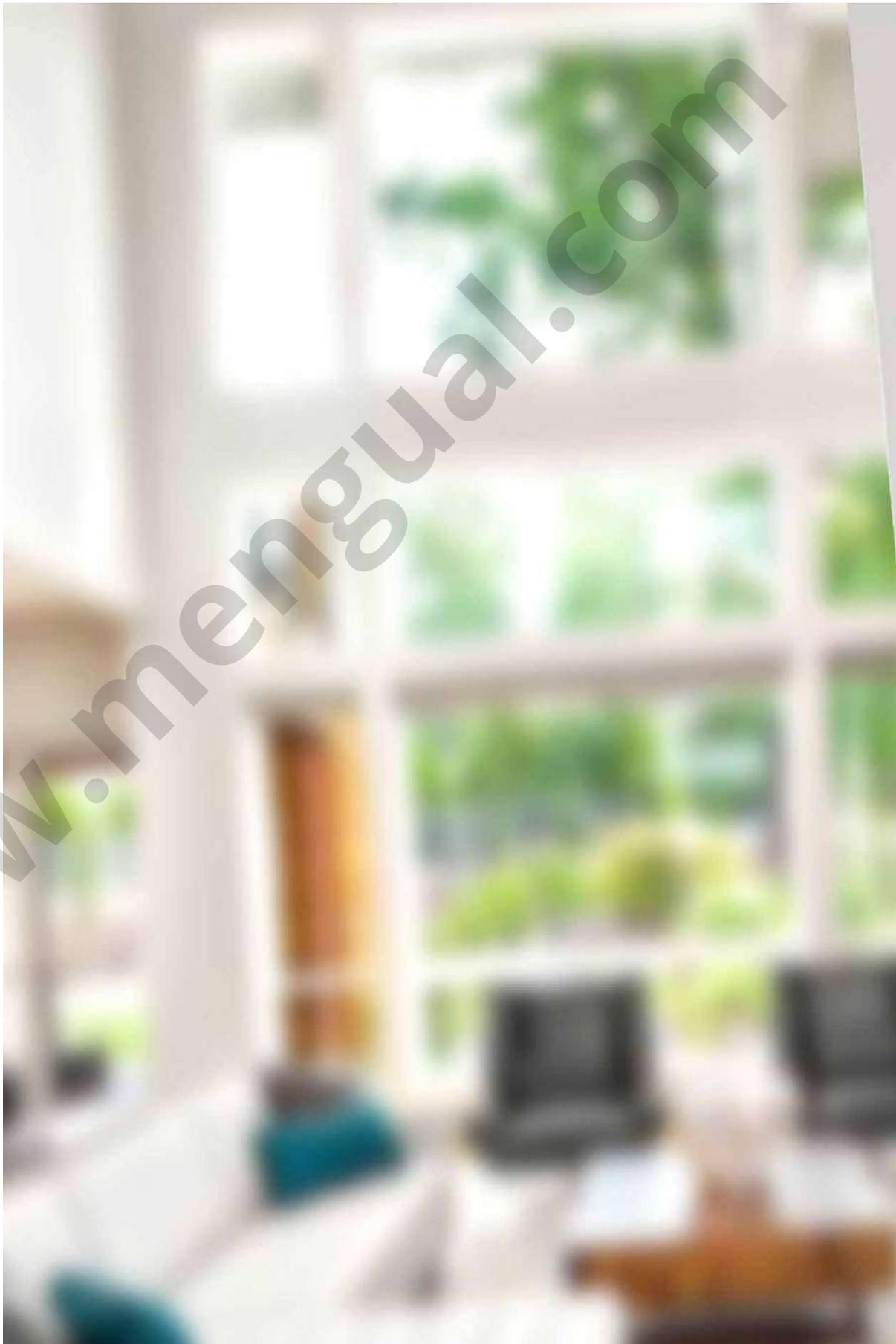

TENDENZA 214





## TENDENZA 214



Cause  
and effect.

*Causa  
y efecto.*

TID 284



## TENDENZA 214

### **The sweetness herself made a handle**

Its modesty does not take away its strength. An update of ANGOLO's best-seller, perfect combination of planes and curves. A dreamy handle.

### **La dulzura hecha manilla**

*Su modestia no le quita su fuerza. Actualización del best-seller ANGOLO, combinación perfecta de planos y curvas. Manilla de ensueño.*



www.mengual.com



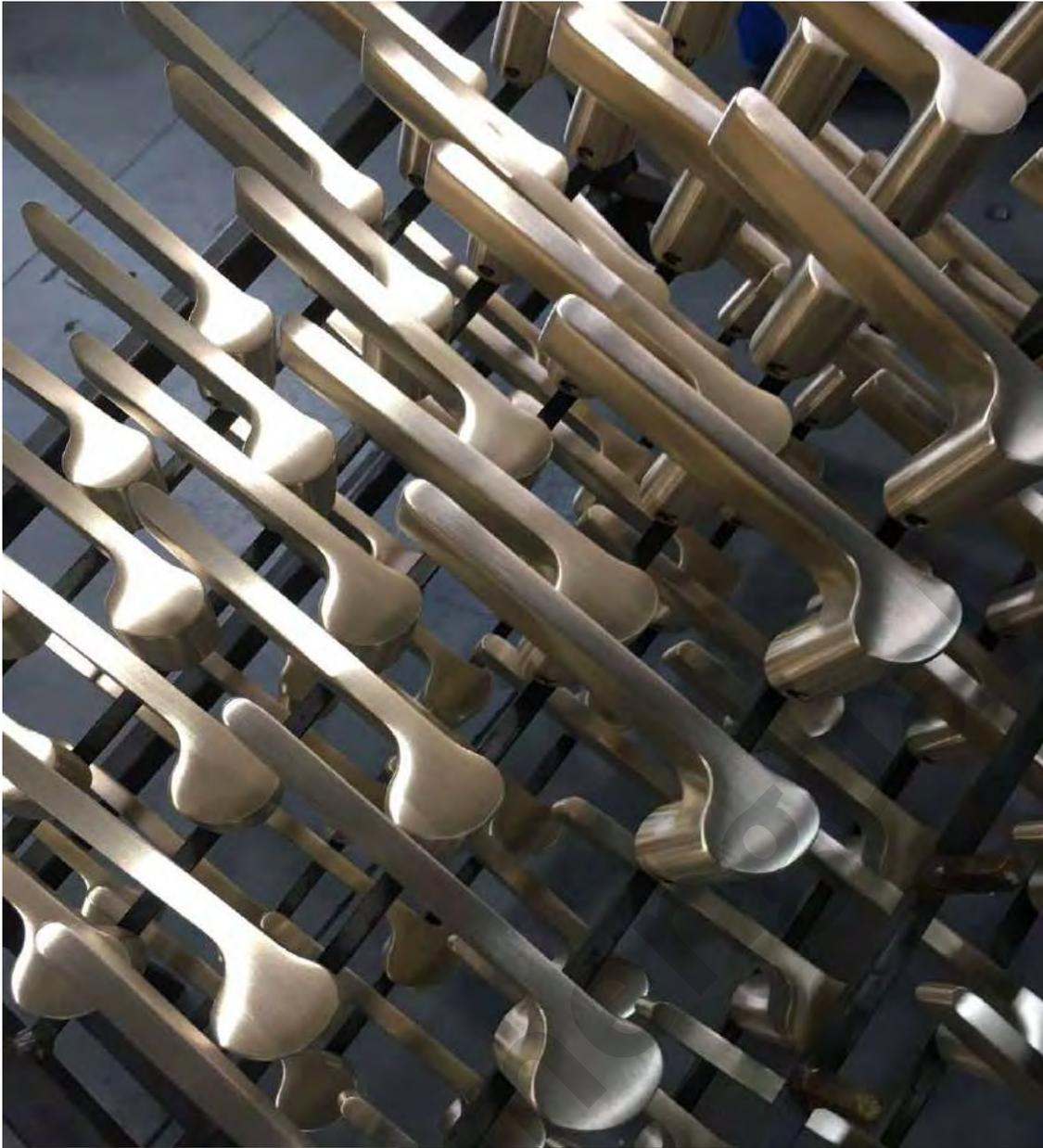

groël

\* TD 285

www.groel.com

**A sky reaching handle**

Contemporary, with rounded shapes and without losing firmness. Named after its silhouette, the falcon.

**Una manilla de altos vuelos**

Contemporánea, de formas redondeadas y sin perder firmeza. De su silueta su nombre proviene, el halcón.

**SOKOL 218**



\*Q 145 | TD 286



#### **Landing in harmony**

The meticulous combination of planes and curves in the most scrupulous way results in a single purpose, design excellence.

#### **Abrazando la armonía**

*La minuciosa combinación de planos y curvas de la forma más escrupulosa da como resultado un propósito único, la excelencia del diseño.*





www.metalgual.com



www.mengual.com

**PIN 232**



● ● PIN 232



\*Q 149 | TD 290





**The glamorous essence of a twist of planes**

The fluid 90° twisted movement of a rectangular bar, will suit you perfectly if you are looking for an audacious interior design.

**La glamurosa esencia de una torsión de planos**

El fluido movimiento de la torsión a 90° de una barra rectangular, te encajará a la perfección si lo que buscas es un interiorismo atrevido.

**The intrinsic beauty of perfect pyramidal  
geometrical shapes**

One, two, THREE. An innovative advanced triangular curve design with avant-garde attributes presenting a linear front. A sigh ...

**La belleza intrínseca de perfectas formas  
piramidales geométricas**

One, two, THREE. Una innovadora curva triangular de diseño avanzado con atributo vanguardista presentando un frente lineal, un suspiro...



\*Q 151 | TD 292

● ● THREE 233





\*G 155 | TD 294

## FLOW 237



### **A robust and noble neck**

Expressive, technical  
and evolved.

### **De cuello robusto y noble**

Expresiva, técnica  
y evolucionada.



www.mengawal.com



SPECIAL 247

[www.mengual.com](http://www.mengual.com)





**SPECIAL 247**



**Delicacy and pureness, the perfect duo**

Its discipline and finesse make it truly Special. With a style denoting minimalism where the most refined curves converge with sweet horizontal surfaces.

**Delicadez y pureza, el dúo perfecto**

*Su disciplina y finura la hacen realmente Special. Con un estilo denotando el minimalismo donde confluyen las más refinadas curvas con dulces superficies horizontales.*





\*Q 159 | TD 296





\*TD 298

**A smooth motion resulting from an oval curled on its own axis**

A poetry of a design with a soft character and a 180° curvature pleasant to the sight and to the touch of your hand.

**Un movimiento suave resultante de un óvalo rizado sobre su propio eje**

Una poesía de diseño con un carácter suave y con una curvatura 180° que satisface tanto a la mirada como a tu mano.



● ● SASHA 255







www.mengual.com



**IBIZA 256**

**Close your eyes, feel the texture**

Bring all your senses into play to immerse yourself in the warmhearted elegance of our model, Ibiza. Ongoing, dynamic and consistent.

**Cierra los ojos, siente la textura**

*Pon en juego todos tus sentidos para sumergirte en la cálida elegancia de nuestro modelo, Ibiza. Actual, dinámico y coherente.*



IBIZA 256



\*TD 299

**The silence of an immaculate curve**

Ideal for those environments in which a curve projecting minimalism is sought.



**El silencio de una curva imaculada**

Ideal para aquellos entornos en los que se busca una curva que proyecta minimalismo.



● ● IDEA 804



\*TD 314

\*TD 315

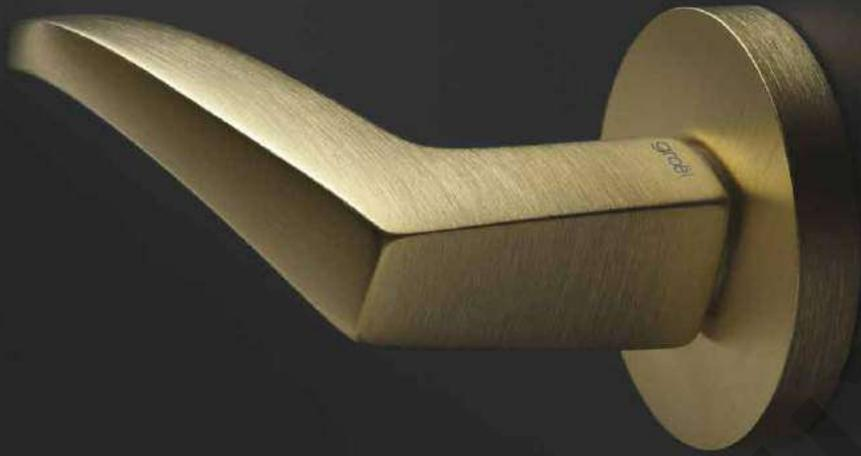

**Diving in glamour**

...and emerging in splendor with this handle combining geometry with seductive curves and absolute delicacy.

**Sumérgete en el glamour**

...y emerge en esplendor con esta manilla combinando geometría con curvas seductoras y delicadeza absoluta.

● ● FEY 806



www.mengual.com





SOFT 807



\*TD 316

www.mer

**Ethereal movement of softness**

...caressing the palm of the hand by virtue of its rounded profile enhanced by its natural simplicity.

**Movimiento etéreo de suavidad**

...acariciando la palma de la mano por su perfil redondeado enaltecido por su natural sencillez.



**A brand new classic**

Sweet, warm, loving; a handle with subtle nuances evoking the endearing peace of home.

**Un nuevo clásico**

Dulce, cálida, amorosa; una manilla de sutiles matices que evoca la entrañable paz del hogar.



NINA 811



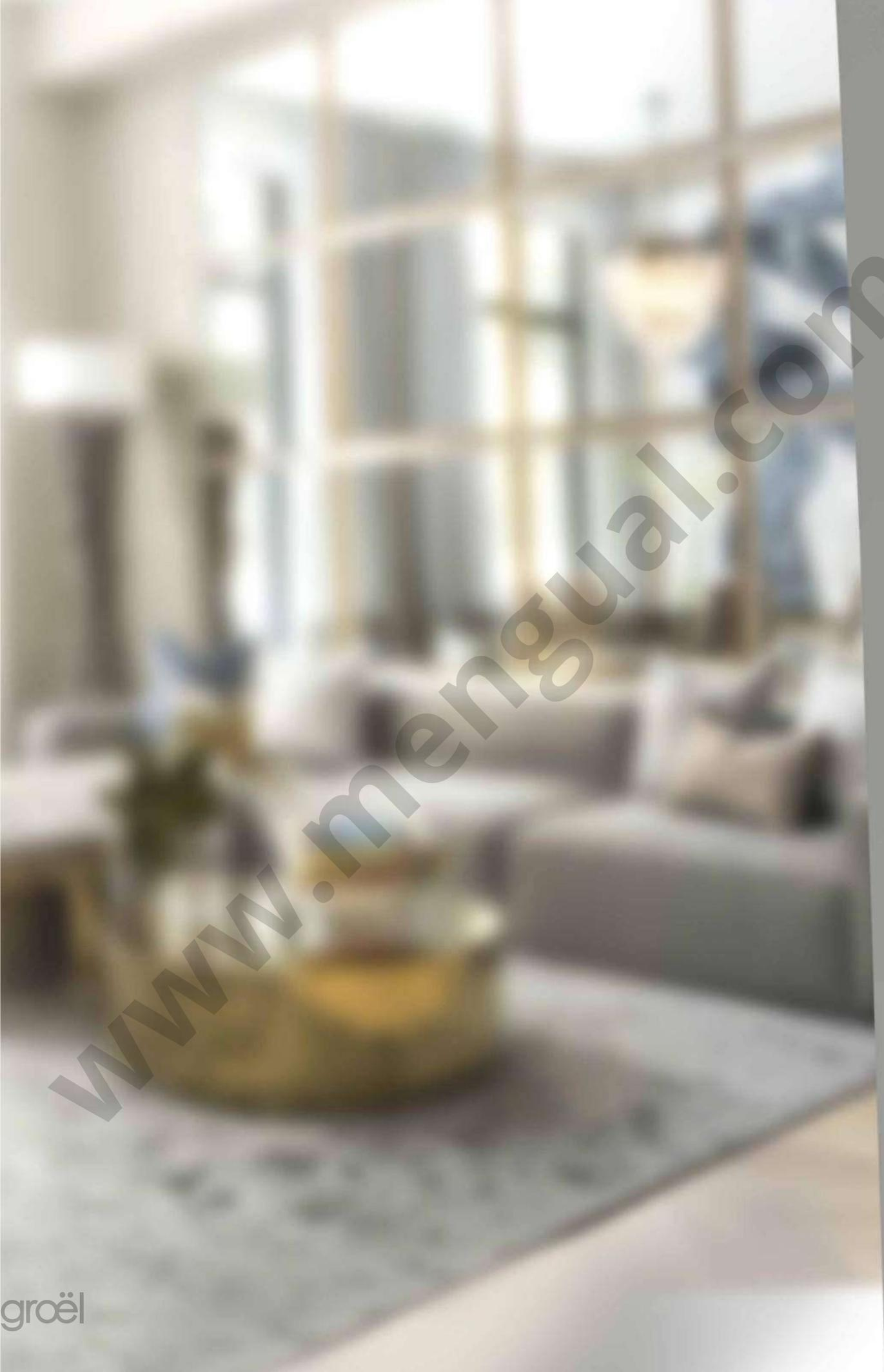



ROBY 812



[www.menggual.com](http://www.menggual.com)



\*TD 320

### **Indulgence and confluence**

Inspiration that develops touching results. Pure lines with impetus, security and as well as noble and forceful.

### **Indulgencia y confluencia**

Inspiración desarrolladora de resultados conmovedores. Puras líneas con ímpetu, seguridad y a su vez noble y contundente.

ROBY 812





[www.mengawal.com](http://www.mengawal.com)

**JET 813**



\*TD 321

**Simplicity pushed to the furthest extremity,  
fruitful in elegance.**

*Firm lines projecting tastefulness and politeness alluding  
trilateral shapes while still presenting an amiable tone owing to  
the sweetness of its neck. The exquisiteness of a design.*

**Sencillez empujada a la más lejana extremidad,  
fructífera en elegancia.**

*Firmeza de líneas con proyección elegante y cordial  
insinuando formas trilaterales sin dejar de presentar un tono  
amable por su dulce cuello. La exquisitez de un diseño.*



● ● BACI 814









BACI 814



## BACI 814



**Modern minimalism partnered with  
the softness of a kiss**

The pleasure of choosing the colour that you like the most from the extensive BACI range. Simplicity and unparalleled style, a compendium of discretion.

**Minimalismo moderno aliado con  
“la gentileza di un bacio”.**

La satisfacción de poder elegir el color que más te gusta con la extensa gama de BACI. Sencillez y estilo inigualable, un compendio de sobriedad.

\*Q 163 | TD 322





**The distended sweetness of geometry**

Investing time in seeing beauty and surrounding yourself with it, will give you life.

**La dulzura distendida de la geometría**

Invertir tiempo en ver la belleza y rodearte de ella, te dará vida.

\*Q 167 | TD 324

● ● DADÁ 815





[www.menahual.com](http://www.menahual.com)

\*TD 326



## IPNOS 816

**Vigor, vitality and functionality in all its splendour**

A design is not only visual art, but more importantly:  
functional beauty.

**Vigor, vitalidad y funcionalidad en todo esplendor**

*Un diseño no es únicamente arte visual, sino más  
importante aún: belleza funcional.*





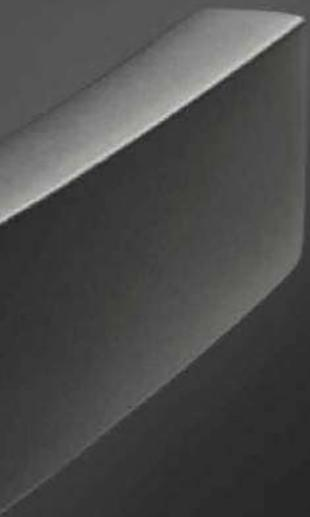

www.mengual.com

ÁNGOLO 817



\*Q 169 | TD 328



**Perfect angles, simply perfect**

A slight curvature on its squared grip symbolizes its meekness despite its robust self.

**Ángulos perfectos, sencillamente perfecta**

Una ligera curvatura en su empuñadura cuadrada, es símbolo de su mansedumbre a pesar de su robusto ser.





**SQUARE DOOR HANDLES**  
*MANILLAS CUADRADAS*

[www.meripostal.com](http://www.meripostal.com)



**Discrete, contemporary and elegant**

The LOG.GIC model presents an ingenious style. A handle with subtly rounded profiles, breaking the barriers of time.

**Discreta, contemporánea y elegante**

El modelo LOG.GIC presenta un estilo ingenuo. Es una manilla de perfiles sutilmente redondeados, con la que rompimos la barrera del tiempo.

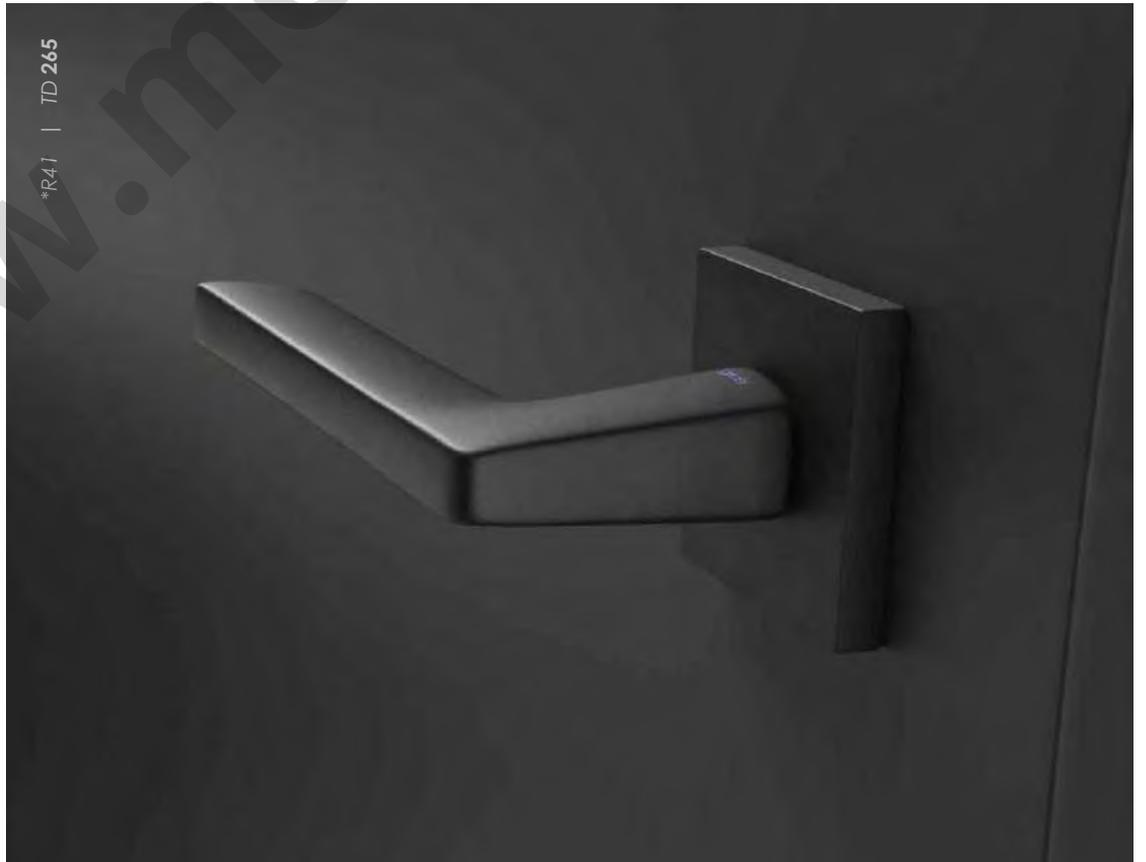



[www.mehagual.com](http://www.mehagual.com)





**Straight lines denoting strength and emphasis**

Robust, firm and compact in design, enhanced by chrome finishes making this handle a perfect model for discrete environments.

**Líneas rectas que denotan fuerza y empaque**

Robusta, firme y de diseño compacto realizado por sus acabados cromados, hacen de esta manilla un modelo perfecto para ambientes sobrios.



\*R 49 | TD 269



\*R 53 | TD 271

**Robust and functional without losing an apex of elegance**

Handles are objects with a life of their own. They imbue your home with their own personality and character. While remaining elegant, its functionally refined profile blends into the ambiance of the most demanding household.

**Robusta y funcional sin perder un ápice de elegancia**

Las manillas son objetos con vida propia. Impregnan tu hogar de personalidad y carácter propio. Sin dejar de ser elegante, su funcionalidad de perfil depurado, se funde en el ambiente del hogar más exigente.

SENS.SO 135



www.mengjual.com

● ● PLANO 137







**The minimalism of three dimensional planes**

The intersection between a cube and a plane in space results in a simple three-dimensionally structured handle that will not go unnoticed. Extreme simplicity.

**El minimalismo de planos tridimensionales**

La intersección entre un cubo y un plano en el espacio da como resultado una manilla sencilla con estructura tridimensional que no pasará desapercibida. Simplicidad extrema.





## FILA 147



\*R 61 | TD 275

### **Subtle, light and refined**

Owing to its vast range of finishes, this model suits any type of decoration and stands out for its simplicity and purity of lines. Popular for its originality in design. A wise choice.

### **Sutil, ligera y refinada**

*Para cualquier tipo de decoración con su vasta gama de acabados, destaca por su sencillez y pureza de líneas. Popular por su original diseño. Una elección acertada.*



\*R 63 | TD 277

**Emphatic and pleasant to the touch**

A wink to every lover of delicate curves on planes.  
A model with character, but simple and natural.

**Enfática y agradable al tacto**

*Un guiño para todos los amantes de delicadas  
curvas del plano. Un modelo con carácter, pero  
simple y natural.*



www.mengjual.com

TD 279



**The pleasure of a flawless balance**

Juxtaposition of orthogonal planes defying the laws of gravity which result in a perfect balance.

**El placer de un equilibrio perfecto**

*Juxtaposición de planos ortogonales desafiantes de las leyes de la gravedad que resultan a la vista en un balance perfecto.*

● ● NADIA 201



W

\*R 65 | TD 281

**Stands out for its rounded angles and moderation**

Subtle in appearance with perfect proportions, rounded angles and pleasant to the touch. A balanced design. Simplicity brought to the extreme.

**Destaca por sus ángulos redondeados y moderación**

*De apariencia sutil pero con proporciones perfectas, ángulos redondeados y agradable al tacto. Un diseño equilibrado. La simplicidad llevada al extremo.*

● ● SLIM 204



## STRIP 213

\* TD 283



### **Bold with sharp lines, a fierce attitude**

Its peculiar angular shape at the front of the handle, brings a shameless character to any door.

### **Atrevida con líneas afiladas, una actitud feroz**

Su peculiar forma angular en el frente de la manilla, aporta un carácter descarado a cualquier puerta.





\*R 75 | TD 287



**Smooth with finesse and prestige**

The meticulous combination of planes and curves way achieves our single purpose, design excellence.

***Liviana con donaire y prestancia***

*La minuciosa combinación de planos y curvas de la forma más escrupulosa da como resultado un propósito único, la excelencia del diseño.*



### **Geometric and sophisticated**

As its name implies, an authentic challenge to geometry in view of the perfect fit of two emblematic pieces that are correspondent with each other.

### **Geométrica y sofisticada**

Tal y como su nombre lo indica, un auténtico desafío a la geometría por el perfecto encaje de dos emblemáticas piezas que "Quadran" entre sí.



\*TD 289

● ● QUADRA 227





PIN 232



**An inspiring flowing motion**

The fluid 90° twisted movement of a rectangular bar, will suit you perfectly if you are looking for an audacious interior design.

**La fluidez de un movimiento inspirador**

El fluido movimiento de la torsión a 90° de una barra rectangular te encajará a la perfección si lo que buscas es un interiorismo atrevido.







www.mengual.com

THREE 233



## THREE 233

### **A triangular and advanced curve design with an avant-garde attribute**

The intrinsic beauty of perfect pyramidal  
geometrical shapes.

### ***Una curva triangular de diseño avanzado con atributo vanguardista***

*La belleza intrínseca de perfectas formas  
piramidales geométricas.*



\*R 81 | TD 293











## FLOW 237

**A robust and noble neck.**

**Expressive, technical and evolved**

Functionality is not always beautiful, but what's beautiful is always functional. That is why we firmly believe that beauty has the power to enhance anyone's lifestyle.



**De cuello robusto y noble.**

**Expresiva, técnica y evolucionada**

*Lo funcional no es siempre bello, pero lo bello siempre es funcional. Por eso creemos firmemente que la belleza tiene el poder de mejorar el estilo de vida de cualquier persona.*

[www.mengual.com](http://www.mengual.com)





SPECIAL 247



www.meridional.com

\*R85 | TD 297



www.menggroel.com



groel



## SPECIAL 247



### **Discipline and purity fused in a single entity**

Its discipline and finesse make it truly Special. With a style denoting minimalism where the most refined curves converge with sweet horizontal surfaces.

### **Disciplina y pureza fusionadas en una única entidad**

*Su disciplina y finura la hacen realmente "special", con un estilo denotando el minimalismo donde confluyen las más refinadas curvas con dulces superficies horizontales.*

[www.menggroel.com](http://www.menggroel.com)





BACI 814

www.meritgual.com

● ● BACI 814

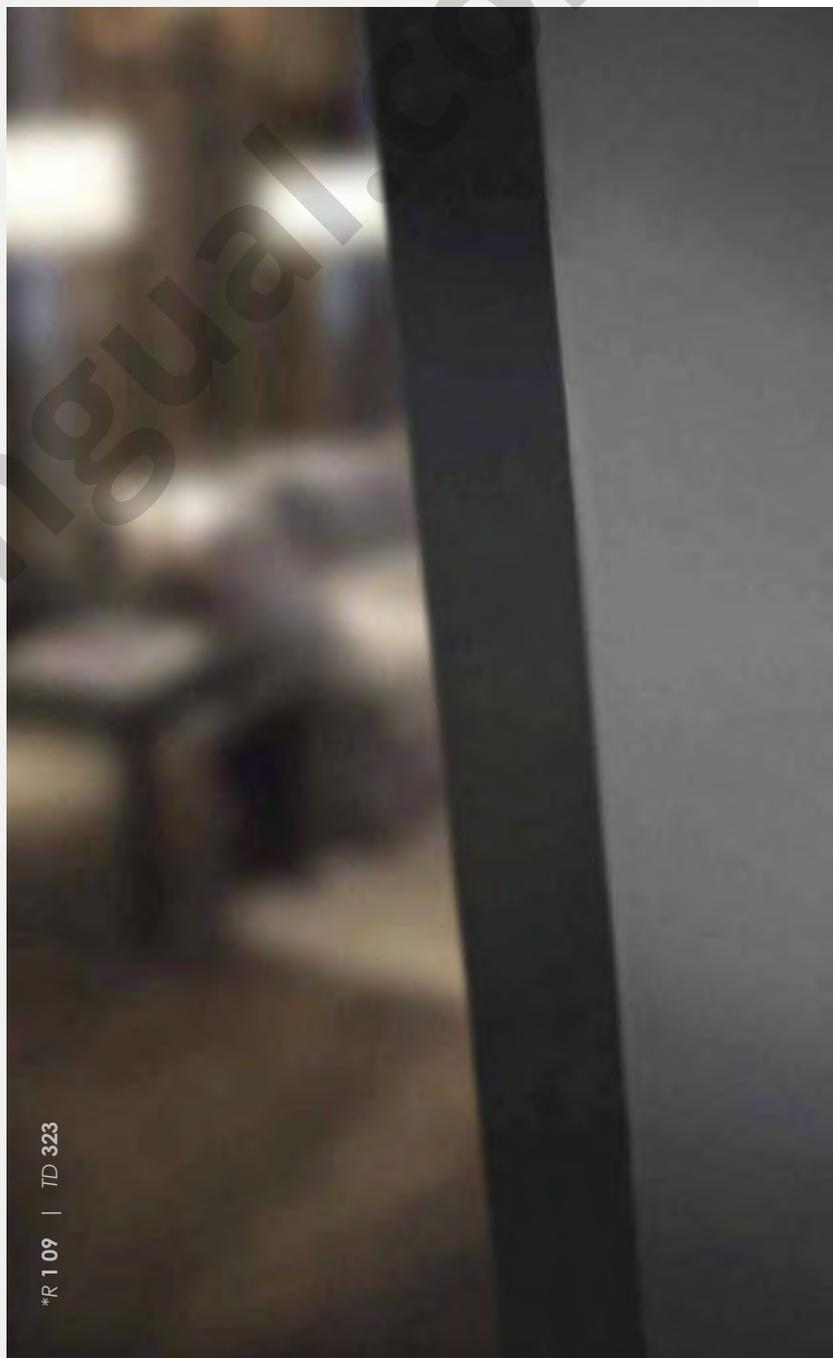

\*R 1 09 | TD 323

**Modern minimalism partnered  
with the softness of a kiss**

The pleasure of choosing the colour that you like the most from the extensive BACI range. Simplicity and unparalleled style, a compendium of discretion.

**Minimalismo moderno aliado con  
"la gentileza di un bacio".**

La satisfacción de poder elegir el color que más te gusta con la extensa gama de BACI. Sencillez y estilo inigualable, un compendio de sobriedad.





\*R115 | TD 322

www.menborg.com

groël



## DADÁ 815

### **The distended sweetness of geometry**

Investing time in seeing beauty and surrounding yourself with it, will give you life.

### **La dulzura distendida de la geometría**

Invertir tiempo en ver la belleza y rodearte de ella, te dará vida.



\*R 115 | TD 325

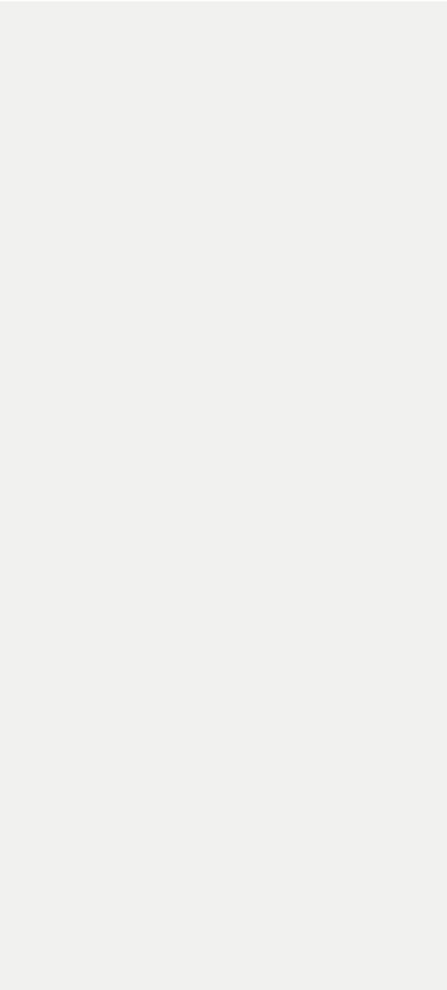

[www.menggual.com](http://www.menggual.com)



ÁNGOLO 817



www.metalgal.com

groël

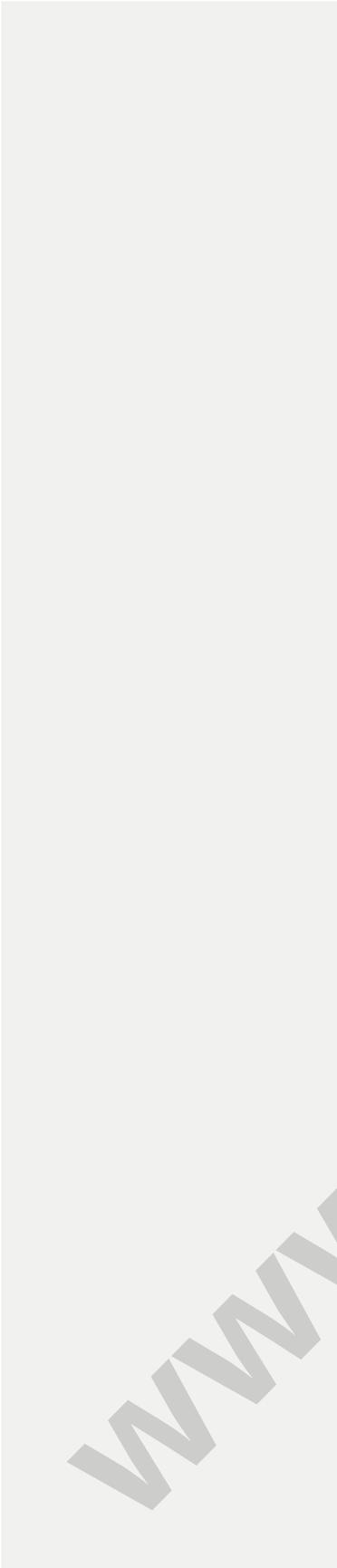

\*R 121 | TD 329

## ÁNGOLO 817



### **Perfect angles, simply perfect**

A slight curvature on its squared grip symbolizes its meekness despite its robust self.

### **Ángulos perfectos, sencillamente perfecta**

Una ligera curvatura en su empuñadura cuadrada, es símbolo de su mansedumbre a pesar de su robusto ser.



# ATELIER

by groël

[www.mensjournal.com](http://www.mensjournal.com)



\*TD 300

**The golden XIXth century conoid design**

A collection of experiences and diverse historical periods without barriers and without losing relevance.

**Magnífico diseño conoide del siglo XIX**

Una colección de experiencias y de diversos periodos históricos sin barreras y sin perder actualidad.



● ● TROMBETTA 510



**The revolution of  
a timeless classic**

Fashion becomes lost in time, while a true  
own style lasts forever.

**La revolución de  
un clásico atemporal**

*Las modas se pierden en el tiempo, mientras  
que un estilo propio y verdadero perdura  
eternamente.*



\*TD 301



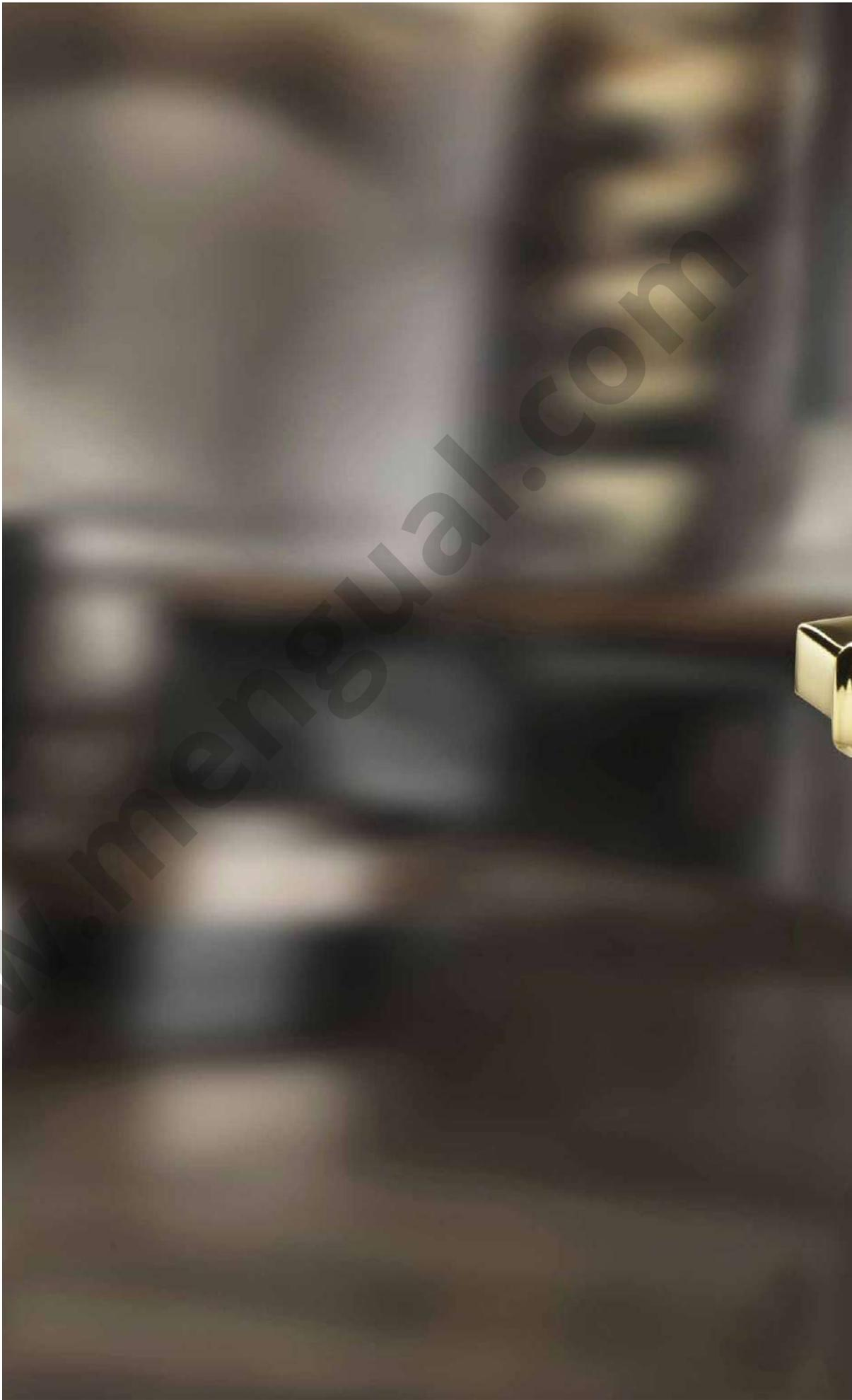

● ● OTTO 528





## OTTO 528

### **A laudable reminiscence of the past.**

A classic modernised trend, entirely beautiful and functional. It's time to join the new design Revolution.

### **Una encomiable reminiscencia al pasado**

Clásica tendencia rejuvenecida, y repleta de belleza y funcionalidad. Es hora de unirse a la nueva Revolución del diseño.



\*TD 302





\*TD 303

**Historical glimpses,  
alluring charms**

A design acknowledging tradition. Meticulous and radiant details on the handle's grip, brought to the vanguard.

**Destellos históricos,  
encantos que fascinan**

*Diseño que no niega la tradición. Meticulosos y radiantes detalles en la empuñadura, llevado a la vanguardia.*





www.mercurial.com



**VASILISA 540**



## VASILISA 540

***A cylindrical artful conception with a romantic hint***

For a relaxed ambiance. The golden quality rule of design is minimalism.

***Una ingeniosa concepción cilíndrica con un toque romántico***

Para un ambiente relajado. La regla de oro de un diseño de calidad es el minimalismo.







\*TD 305

#### **The modern decor of 1925**

A classic inspired by the famous 1920s of a Paris brimming with ideas, industrial lines and graphic design.

#### **La modernidad decorativa de 1925**

*Un clásico inspirado en los célebres años 20 de un París rebosante de ideas, de líneas industriales y diseño gráfico.*

● ● ARTDÉCO 550



www.merisqual.com



\*TD 306

**An Empire State of mind**

"...will make you feel brand new  
thick lines will inspire you,  
hear it for, New York!".

**Un estado de mente a lo Empire State**

"...te hará sentir como nuevo  
su grosor de líneas te inspirará,  
con todos ustedes, Nueva York!".



NEW YORK 555



**The elegance one falls in love with**

The purity of artwork is innate. A design that outshines for the sake of its simplicity.



**La elegancia que enamora**

La pureza de una obra de arte es de carácter innato. Un diseño que eclipsa por su sencillez.

● ● NONNA 560



www.112.com

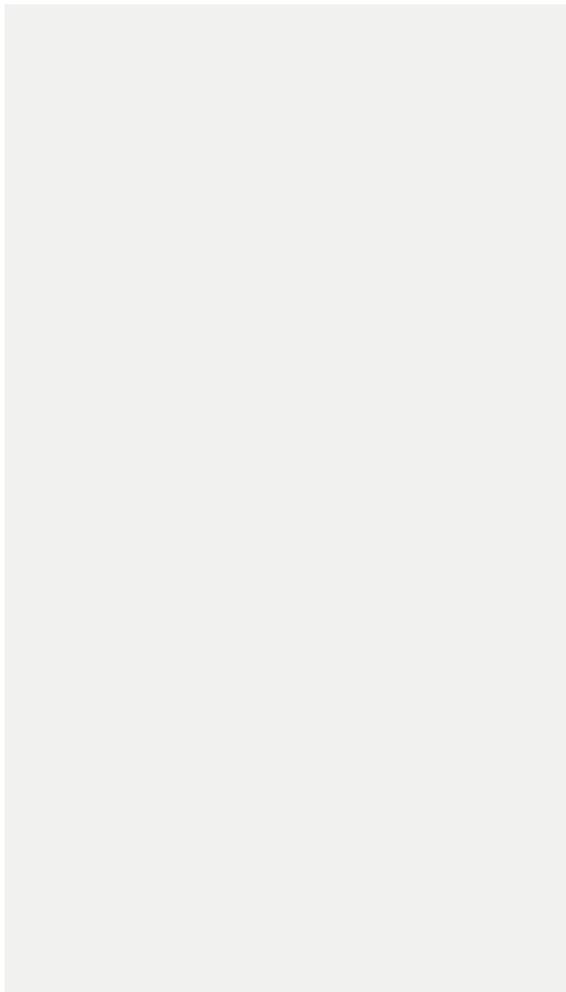

**The contemporary  
design of a classic**

We can't talk about creation without a great deal of love or obsession. Its harmony of consecutive lines and its turned neck make it brilliant.

**Diseño contemporáneo  
de un clásico**

*Sin amor ni obsesión en gran proporción no podemos hablar de creación. Brillante por su propia armonía de líneas consecutivas y cuello torneado.*



\*TD 308

● ● MALIKA 570



**A British-flavoured picturesque courtesy**

Governor by her individual nature, she will imbue your home with the presence of her legacy.

**Amabilidad pintoresca con sabor británico**

Gobernadora por su singular naturaleza, impregnará tu hogar con la presencia de su legado.



\*TD 309

● ● ELISABETH 580



www.hoppe.com

**The minimal expression of a perfect tandem**

Perfect combination of certified ebony wood contrasted with brass, satin or polished nickel; made with the highest delicacy and precision

**La mínima expresión de un tándem perfecto**

Perfecta combinación de madera de ébano certificada contrastada con latón, níquel satinado o brillo; elaborada con la más alta delicadeza y precisión.





● ● CHÉRIE 590



\*TD-310

www.menggal.com

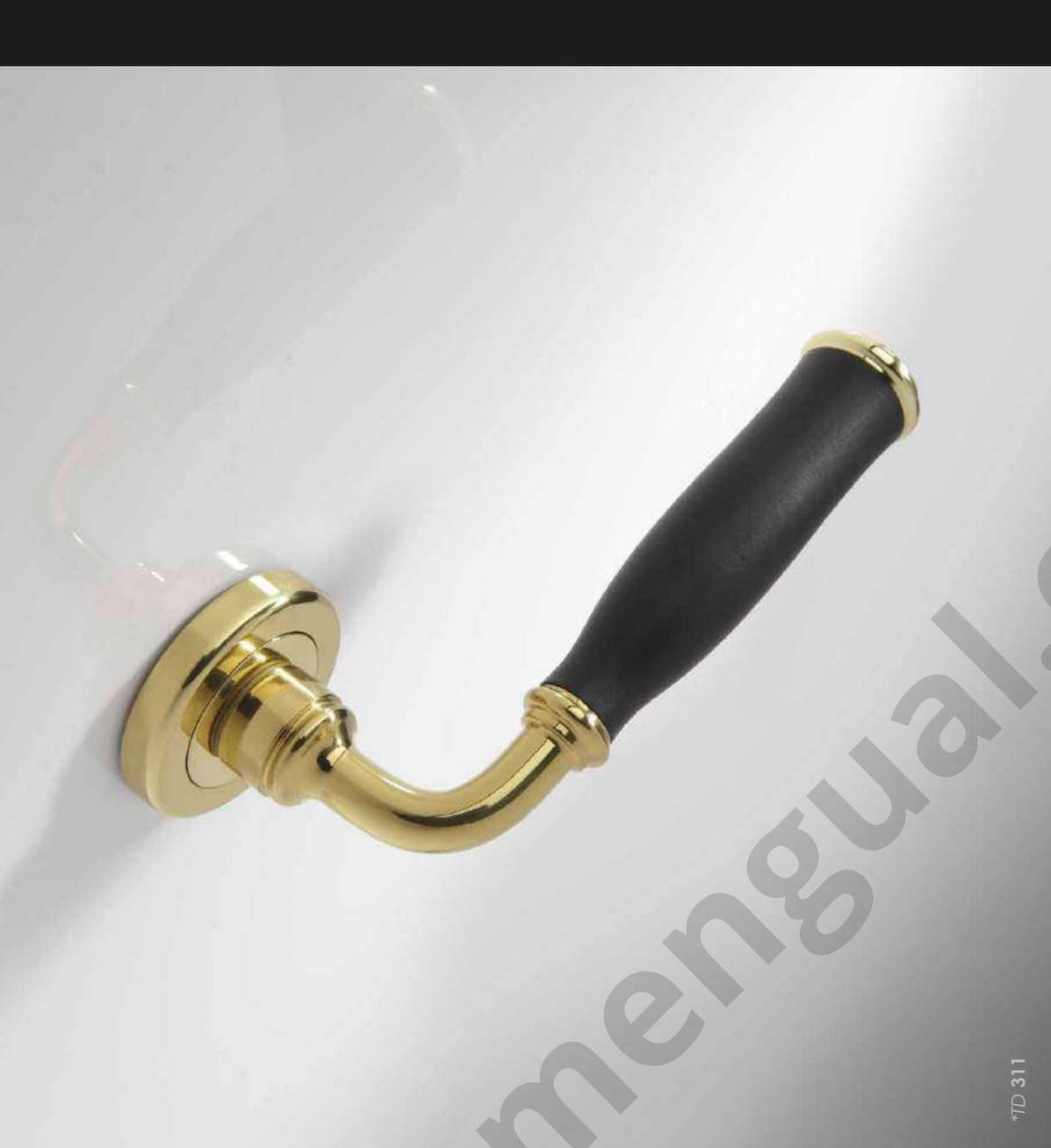

mengual.com

\*TD 311

**A classic made wood**

Styles do not always have to be categorised. Sometimes you just have to set them free, listen to the story behind and what each of them have to tell us.

**Un clásico hecho madera**

Los estilos no han de ser siempre categorizados. A veces solo hay que dejarlos libres, escuchar la historia que hay detrás y lo que cada uno nos tiene que contar.



● ● DOVE 595



www.rengual.com

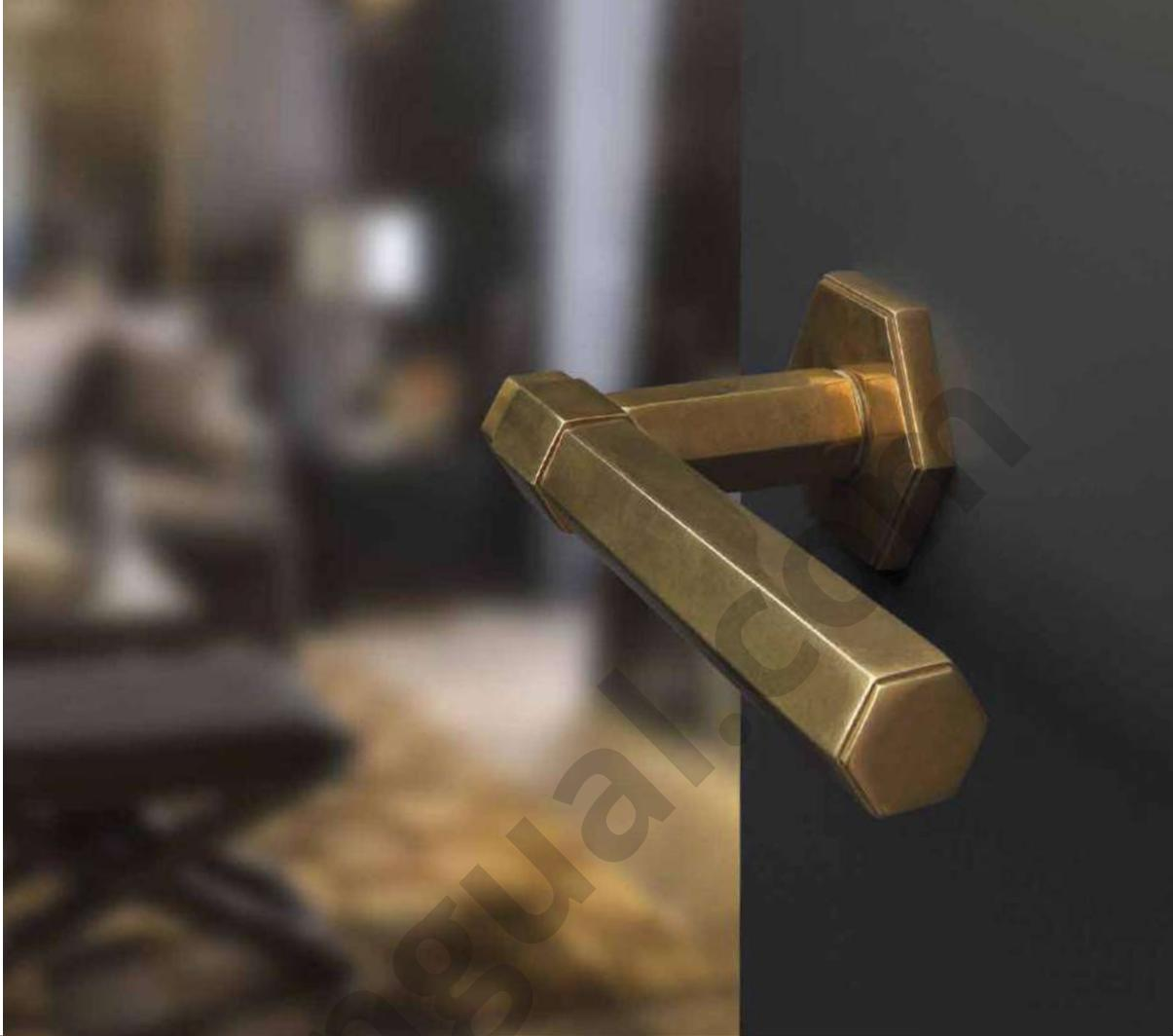

\*TD 312



## ESPUCH 616



### **An origin and heart from Alicante**

The beauty of the pure symmetry of a hexagon turned into a handle. For very demanding and avant-garde environments.

### **De origen y corazón de Alicante**

La belleza de la pura simetría de un hexágono hecha manilla. Para ambientes muy exigentes y vanguardistas.





**RUSTIC DOOR HANDLES**  
*MANILLAS RÚSTICAS*

[www.meripostal.com](http://www.meripostal.com)

**Quality and appeal,  
a true classic remains  
ageless over time**

Classic, rustic and powerful  
in design, with a unique  
porcelain grip of the highest  
quality.

**Calidad y atracción,  
un verdadero clásico  
no envejece frente  
al tiempo**

De diseño clásico, rústico  
y poderoso, con una  
empuñadura única en  
porcelana de máxima  
calidad.

\*TD 262





● ● BEL.LA 108





[www.mengual.com](http://www.mengual.com)





## MARÍA 803

**It's all about aesthetics, the nature  
of beauty and good taste**

Proportioned handle that makes tradition with  
reminiscence of a golden era.

**La estética lo es todo, la naturaleza  
de la belleza y el buen gusto**

Proporcionada manilla que hace tradición con  
reminiscencias a una época dorada.



\*TD 313



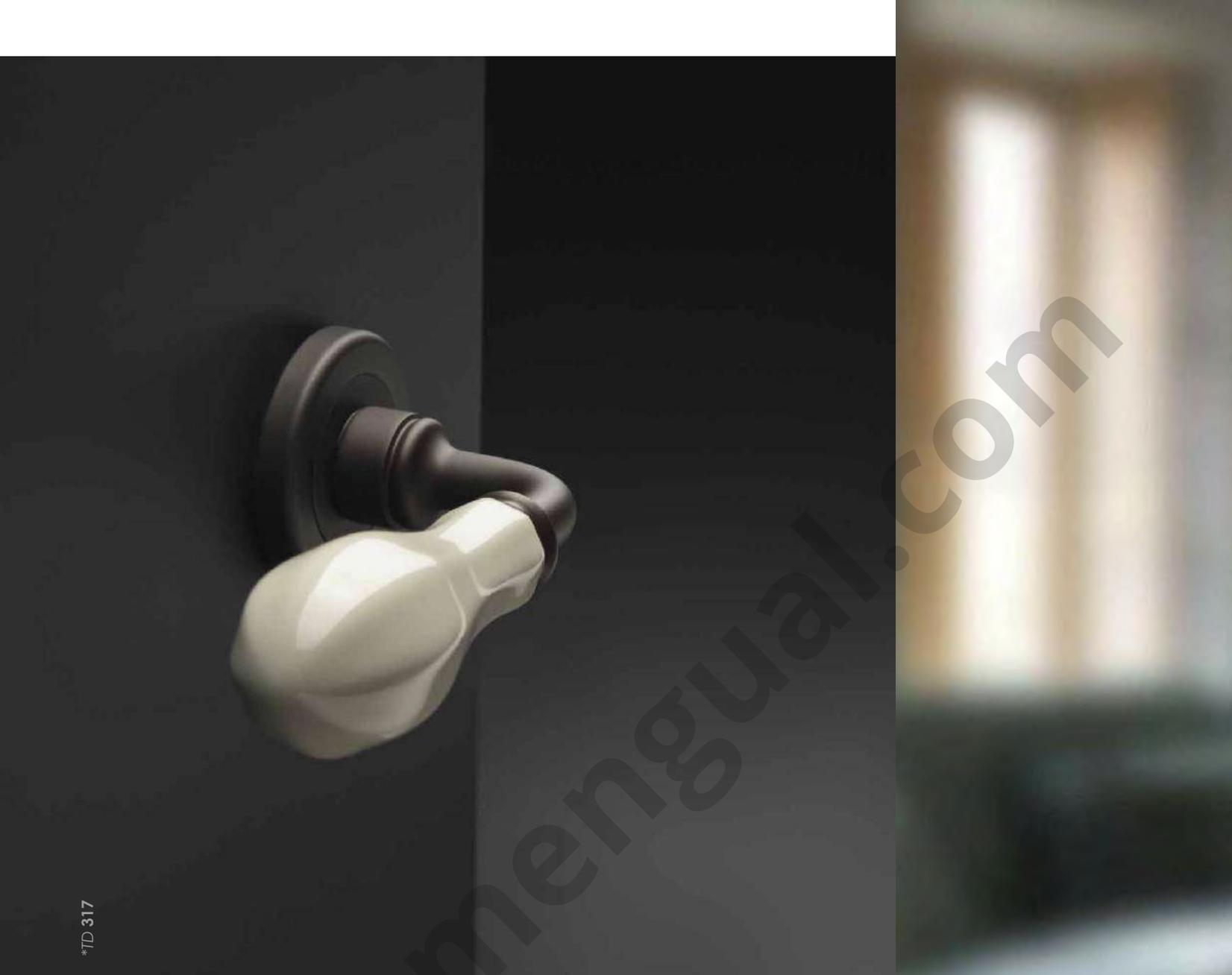

\*TD 317

**Classic and distinguished, a world of reminiscences**

A charming pearl effect owing to its porcelain grip, an authentic jewel.

**Clásica y distinguida, un mundo de reminiscencias**

Un efecto de perla embaucadora por su empuñadura en porcelana, una auténtica joya.



www.merajual.com







KILTO 809



\*TD 318

#### **Transcending time and fashion**

A perfect fit for classic and modern environments. Standing out for providing that traditional detail that completes the conventional design.

#### **Trascendiendo el tiempo y las modas**

*Encaja a la perfección en ambientes clásicos y modernos. Destaca por aportar ese detalle tradicional que completa el diseño convencional.*





PULL HANDLES  
MANILLONES

[www.meripgual.com](http://www.meripgual.com)

## BEL.LA 110m



**Quality and appeal, a true classic remains ageless over time**

Classic, rustic and powerful in design, with a unique porcelain handle of the highest quality.

**Calidad y atracción, un verdadero clásico no envejece frente al tiempo.**

De diseño clásico, rústico y poderoso, con una empuñadura única en porcelana de máxima calidad.

\*TD 330

**Geometric, squared and sophisticated**

As its name implies, an authentic challenge to geometry in view of the perfect fit of two emblematic pieces that are correspondent with each other.

**QUADRO 127m**

**Geométrica, cuadrada y sofisticada**

Tal y como su nombre lo indica, un auténtico desafío a la geometría por el perfecto encaje de dos emblemáticas piezas que "quadran" entre sí.

\*TD 331

● ● PLANO 137m

\*TD 332



**Minimalism, serenity and practicality**

The intersection between a cube and a plane in space results in a simple three-dimensionally structured pull handle that will not go unnoticed. Extreme simplicity.

**Minimalismo, serenidad y practicalidad**

La intersección entre un cubo y un plano en el espacio da como resultado un manillón sencillo con estructura tridimensional que no pasará desapercibida. Simplicidad extrema.



\*TD 333

**The utilitarian depiction  
of individuality and brilliance**

Full-fledged pragmatic. Distinguished minimalist design with straight lines providing an ambiance of seriousness and modernity.

**La representación utilitarista  
de individualidad y esplendor**

Pragmática en toda regla. Distinguido diseño minimalista con líneas rectas proporcionando un ambiente de seriedad y modernidad.

## TORSO 235m



\*TD 334

**Pure lines,  
twisted  
and captivating**

A captivating and engulfing 90° turn enhancing the beauty and elegance of this pull handle.

**Líneas puras,  
torsionadas  
y cautivadoras**

Un giro 90° atrapante y envolvente enaltecendo la belleza y elegancia de este manillón.





## IBIZA 256m

**Close your eyes,  
feel the texture**

Bring all your senses into play to immerse yourself in the warmhearted elegance of our model, Ibiza. Ongoing, dynamic and consistent.

**Cierra los ojos,  
siente la textura**

Pon en juego todos tus sentidos para sumergirte en la cálida elegancia de nuestro modelo, Ibiza. Actual, dinámico y coherente.





## TROMBETTA 510m

### **The conoid design from the XIXth century**

A collection of experiences and diverse historical periods without barriers and without losing relevance.

### **El diseño conoide del siglo XIX**

Una colección de experiencias y de distintos periodos históricos sin barreras y sin perder actualidad.

\*TD 336



**MANEGA 520m**

**The revolution of  
a timeless classic**

Fashion becomes lost in time,  
while a true own style  
lasts forever.

**La revolución de  
un clásico atemporal**

*Las modas se pierden en el  
tiempo, mientras que un estilo  
propio y verdadero perdura  
eternamente.*



## OTTO 528m



\*TD 338

### **A laudable reminiscence of the past**

A classic modernised trend, entirely beautiful and functional. It's time to join the new design Revolution.

### **Una encomiable reminiscencia al pasado**

Clásica tendencia rejuvenecida, y repleta de belleza y funcionalidad. Es hora de unirse a la nueva Revolución del diseño.

## PALLINE 533m

### **Historical glimpses, alluring charms**

A design acknowledging tradition. Meticulous and radiant details on the handle's grip, brought to the vanguard.

### **Destellos históricos, encantos que fascinan**

*Diseño que no niega la tradición. Meticulosos y radiantes detalles en la empuñadura, llevado a la vanguardia.*



\*TD 339

## VASILISA 540m

**A cylindrical artful conception with an archaic hint**

For a relaxed ambiance. The golden quality rule of design is... minimalism.

**Una ingeniosa concepción cilíndrica con un toque arcaico**

Para un ambiente relajado. La regla de oro de un diseño de calidad es el ... minimalismo



\*TD 340



## ARTDÉCO 550m

### **The modern decor of 1925**

A classic inspired by the celebrated 20s of a Paris brimming with ideas, industrial lines and graphic design.

### **La modernidad decorativa del año 25**

Un clásico inspirado en los célebres años 20 de un París rebosante de ideas, de líneas industriales y diseño gráfico.



\*TD 341

NONNA 560m



\*TD 342

**The modesty one falls in love with**

The purity of artwork is innate.  
A design that outshines for the sake  
of its simplicity.

**La modestia que enamora**

*La pureza de una obra de arte es de  
carácter innato. Un diseño que  
eclipsa por su sencillez.*





**Neatness and spontaneity,  
a delightful touch**

The purity of a work of art is innate.  
A design that overshadows its  
simplicity.

**Pulcritud y espontaneidad,  
agradable al tacto**

La pureza de una obra de arte es  
de carácter innato. Un diseño que  
eclipsa por su sencillez.

● ● MALIKA 570m

www.mengual.com



● ● TECNO 801m

\*TD 344



groël



**The symphony of soft curves**

A gallantry and discretion of a pull handle, with a soft touch matching its lines.

**La sinfonía de curvas suaves**

Una galantería y discreción de manillón, con suavidad al tacto en consonancia con sus líneas.



## NUOVO 805m



### **The beguile formality of ergonomic lines**

Sublime touch, contemporary design,  
and high affinity with current interior  
design trends.

### **Formalidad embaucadora de líneas ergonómicas**

Tacto sublime, diseño contemporáneo,  
y de alta afinidad con las tendencias  
actuales de interiorismo.

\*TD 346

## KILTO 809m



### **Transcending time and fashion**

A perfect fit for classic and modern ambiances. Standing out for providing that traditional detail that completes the conventional design.

### **Trascendiendo el tiempo y las modas**

*Encaja a la perfección en ambientes clásicos y modernos. Destaca por aportar ese detalle tradicional que completa el diseño convencional.*

\*TD 348



## MARÍA 810m

**It's all about aesthetics, the nature  
of beauty and good taste**

Proportioned pull-handle making tradition with  
reminiscence to a golden era.

**La estética lo es todo, la naturaleza  
de la belleza y el buen gusto**

Proporcionado manillón que hace tradición con  
reminiscencias a una época dorada.

\*TD 349



## ÁNGOLO 817m



\*TD 350

### **Straight angles extolling functionality with elegance**

A slight curvature on its squared grip symbolizes its meekness despite its robust self.

### **Un ángulo recto enalteciendo la funcionalidad con elegancia**

Una ligera curvatura en su empuñadura es símbolo de su mansedumbre a pesar de su robusto ser.



## LOG.GIC 827m

**Gentle, contemporary,  
nonetheless stylish**

The LOG.GIC model presents an ingenious style. A handle with subtly rounded profiles, breaking the barriers of time.

**Gentil, contemporánea  
no exenta de estilo**

El modelo LOG.GIC presenta un estilo ingenuo. Es un manillón de perfiles sutilmente redondeados, con lo que rompimos la barrera del tiempo.

\*TD 352



\*TD 354

## LIFTER 400C



**Balance between  
appearance and  
functionality.**

*El balance entre  
aparencia y  
funcionalidad.*





DOOR KNOBS - STOPPERS  
*POMOS - TOPES*

[www.meripostal.com](http://www.meripostal.com)



**A decorative and simple style**

A piece that will not go unnoticed on a front door. A perfectly irregular cube.

**Un estilo decorativo y sencillo**

Una pieza que no pasará desapercibida en una puerta de entrada. Un cubo perfectamente irregular.

DÉCO 316



## CUADRO 317



\*TD 356

### **A classic from shape to function**

Balanced and firm door knob in two squared pieces. What a sight!

### **Un clásico de la forma a la función**

Equilibrado y firme pomo de puerta en dos piezas cuadradas. Todo un cuadro!





\*TD 357

**Six faces full of purity**

With a dice, metaphorically chances are left in the hands of fate, and functionally simplicity is left in the hands of minimalism.

**Seis caras repletas de pureza**

Con el dado, metafóricamente el azar es dejado en manos del destino, y funcionalmente la sencillez es dejada en manos del minimalismo.

**Solidity capable of  
generating sensations**

Colossal should be its name.  
Quadrilateral in shape and  
with rounded ridges, without  
losing a whit of functionality: a  
cubic storm.

**Solidez capaz de  
generar sensaciones**

Colosal debería de ser  
su nombre. De forma  
cuadrilátera y crestas  
redondeadas, sin perder un  
ápice de funcionalidad: una  
tormenta cúbica.

\*TD 358

● ● BIG 335



## WIDE 357

### **Persuasive quadratic silhouette**

The possibility of combining a prominent squared silhouette with a round touch, sweetens the face of this wide knob.

### **Silüeta cubica y persuasiva**

La posibilidad de combinar una silüeta cuadrada prominente con un toque redondo, endulza el rostro de este amplio pomo.





\*TD 360

## DADO 318

### Small distant platonic solid

With a dice, metaphorically chances are left in the hands of fate, and functionally simplicity is left in the hands of minimalism.

### Pequeño distante sólido platónico

Con el dado, metafóricamente el azar es dejado en manos del destino, y funcionalmente la sencillez es dejada en manos del minimalismo.



## CUBE 319

### New minimalist version

... Of a cube, squared shaped, it represents the order of volumes in its mystical fortress.

### La nueva versión minimalista

... De un cubo, de forma cuadrada representa el orden de los volúmenes en su mística fortaleza.



\*TD 361





ACCESSORIES  
ACCESORIOS

[www.meragual.com](http://www.meragual.com)



100 R8B



100 R8BB



100 R3B



100 R3BB



100 RKB



100 RKBB



100 RTB



100 RTBB



100 REB

**Round Escutcheon "B"**  
**Bocallave Redondo "B"**



R8B



RTB



R3B



RKB



REB

61

**Round Escutcheon "BB"**  
**Bocallave Redondo "BB"**



R8BB



RTBB



R3BB



RKBB





100 R8CB



100 R8CBB



100 R2CB



100 R2CBB



100 R4CB



100 R4CBB



100 R18B



100 R18BB



100 RECB

**Squared Escutcheon "B"**  
**Bocallave Cuadrado "B"**



R8CB



R2CB



R4CB



R18B



RECB

**Squared Escutcheon "BB"**  
**Bocallave Cuadrado "BB"**



R8CBB



R2CBB



R4CBB



R18BB



100 R8CD



100 R8CD8



100 RVCD

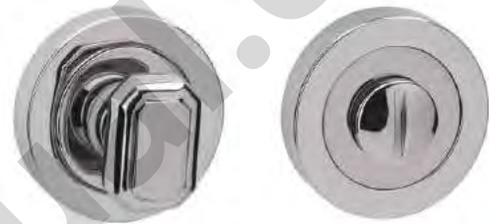

100 RVCD8



100 R8CD6



100 RKCD



100 RTCD

**Round WC Set  
Condensa Redonda**

	$\frac{50}{50}$	$\frac{50}{50}$	$\frac{50}{50}$	$\frac{50}{50}$	$\frac{50}{50}$	$\frac{50}{50}$	$\frac{50}{50}$
50						50	
23						32	
	R8CD	R8CD6	RTCD	RKCD	RVCD	R8CD8	RVCD8



100 R8CCD



100 R2CCD



100 R4CCD



100 R18CD8

www.menglu.com

**Square WC Set**  
**Condena Cuadrada**

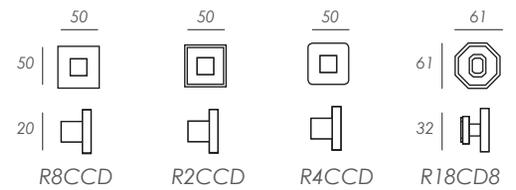



PM



PC



P



PC2



PG



P3



REC



RE

**Backplates  
Placas**

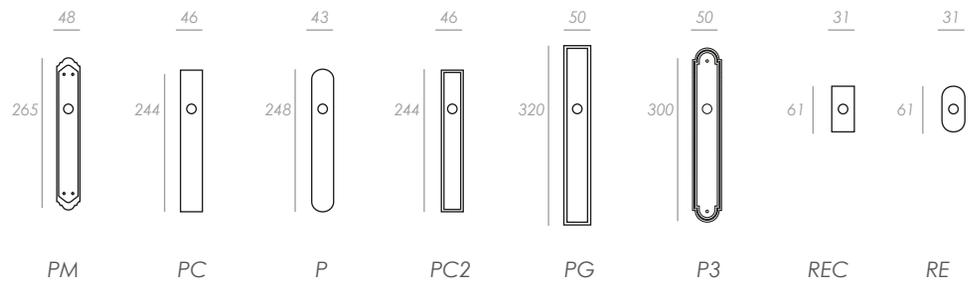



1200 KIT



1200 KITC



1200 KITU



1200 KITUC

**Sliding Door Kit**  
**Kit Puerta Corredera**

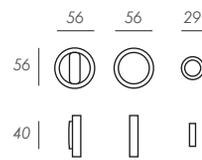

1200 KIT  
1200 KITU

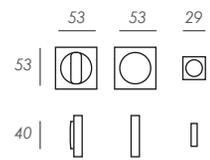

1200 KITC  
1200 KITUC





TECH DATA  
INFO TÉCNICA

[www.merugual.com](http://www.merugual.com)

# BEL.LA 108

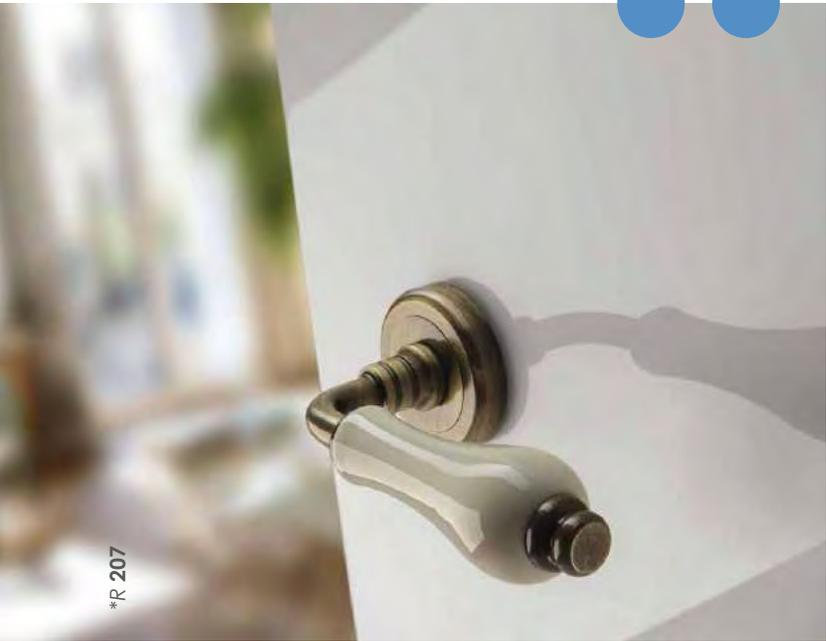

\*R 207



Rose  
Roseta

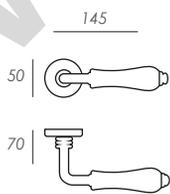

RT

Narrow Rose  
Roseta Estrecha

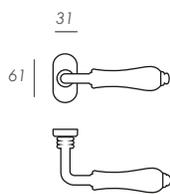

RE

Escutcheon  
Bocallave



RTBB

RTB

WC Set  
Condena



RTCD

Window Handle  
Grisán

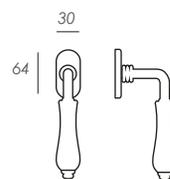

G

Oval Backplate  
Placa Oval

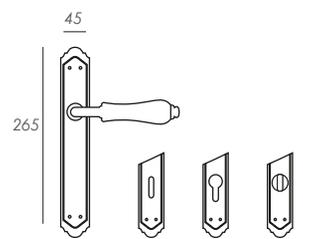

PM

PMBB

PMB

PMCD





FUBL



HIBL



FUCRAQ



HICRAQA



# LOG.GIC 117



\*R 41

PWLP



PWLS



CR



CS



PWIX



BK



WT



Rose  
Roseta

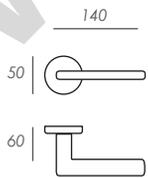

R8

Narrow Rose  
Roseta Estrecha

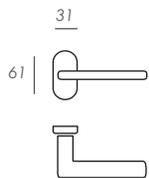

RE

Escutcheon  
Bocallave



R8BB R8B

WC Set  
Condena



R8CD

Window Handle  
Grisán

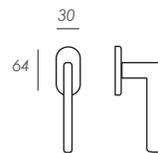

G

Oval Backplate  
Placa Oval

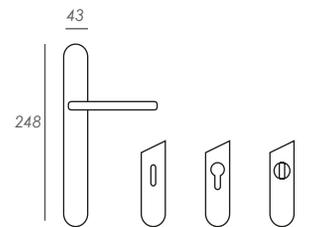

P PBB PB PCD



PWLP

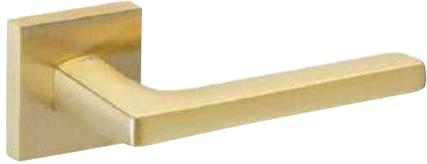

PWLS



CR



CS



PWIX



\*Q 125



BK



WT

Rose  
Roseta

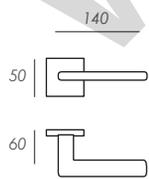

R8C

Narrow Rose  
Roseta Estrecha

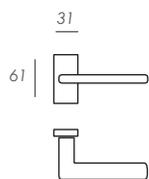

REC

Escutcheon  
Bocallave



R8CBB R8CB

WC Set  
Condensa



R8CCD

Window Handle  
Grisán

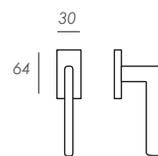

GC

Rectangular Backplate  
Placa Rectangular

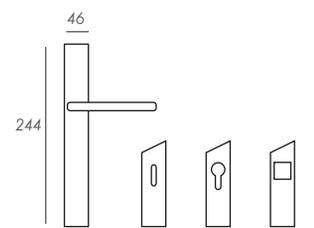

PC PCBB PCB PCCD

# HÉLICE 133



PWLP



PWLS



CR



CS



PWIX



Rose  
Roseta

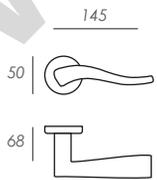

R8

Narrow Rose  
Roseta Estrecha

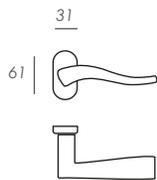

RE

Escutcheon  
Bocallave



R8BB R8B

WC Set  
Condena



R8CD

Window Handle  
Grisán

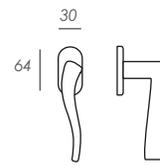

G

Oval Backplate  
Placa Oval

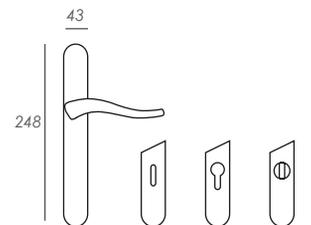

P PBB PB PCD



# TOUCH 134

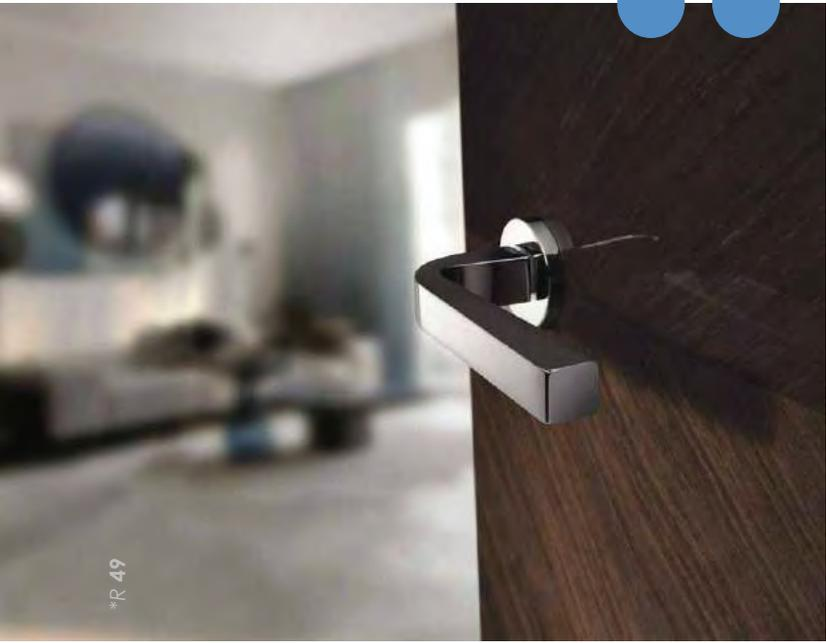

CR



CS



Rose  
Roseta

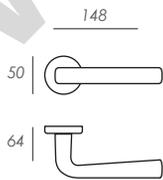

R8

Narrow Rose  
Roseta Estrecha

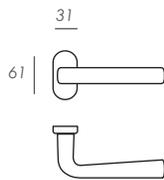

RE

Escutcheon  
Bocallave



R8BB

R8B

WC Set  
Condena



R8CD

Window Handle  
Grisán

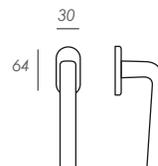

G

Oval Backplate  
Placa Oval

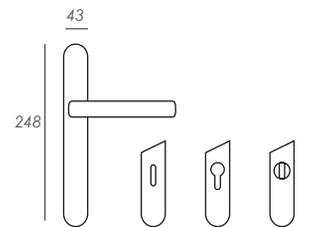

P

PBB

PB

PCD



CR



CS

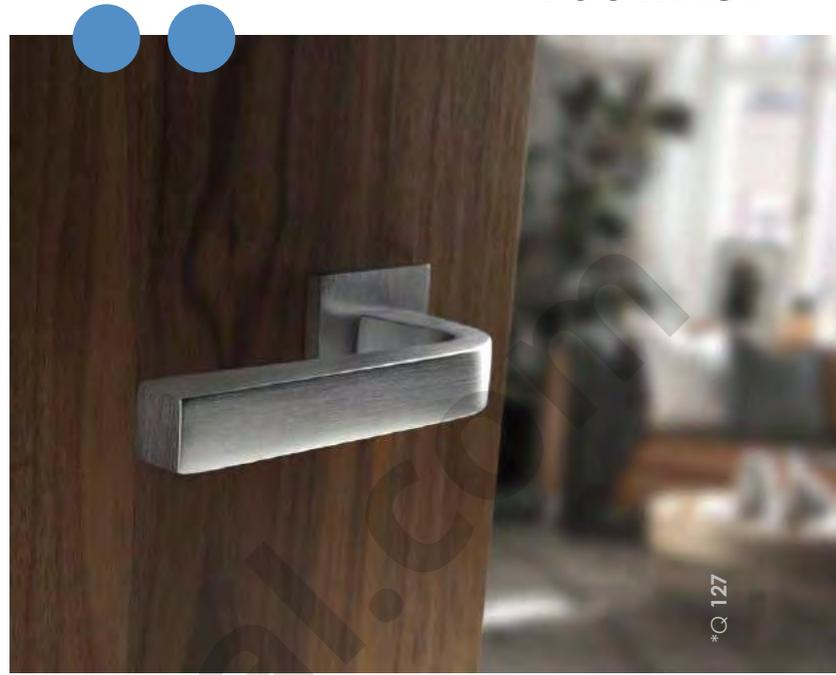

\*Q 127

Rose  
Roseta

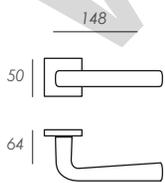

R8C

Narrow Rose  
Roseta Estrecha

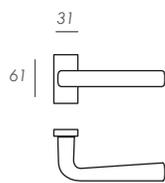

REC

Escutcheon  
Bocallave

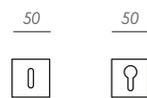

R8CBB R8CB

WC Set  
Condensa



R8CCD

Window Handle  
Grisán

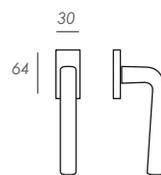

GC

Rectangular Backplate  
Placa Rectangular

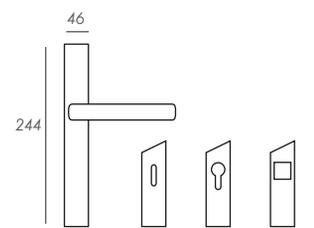

PC PCBB PCB PCCD

# SENS.SO 135



CR



CS



PWIX



BK



WT



Rose  
Roseta

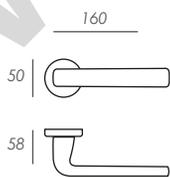

R8

Narrow Rose  
Roseta Estrecha

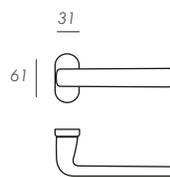

RE

Escutcheon  
Bocallave



R8BB R8B

WC Set  
Condena



R8CD

Window Handle  
Grisán

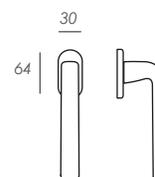

G

Oval Backplate  
Placa Oval

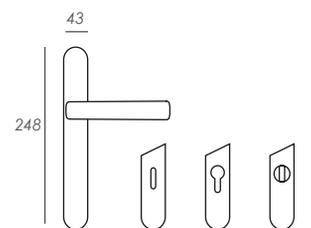

P PBB PB PCD





CR



CS



PWIX



BK



WT

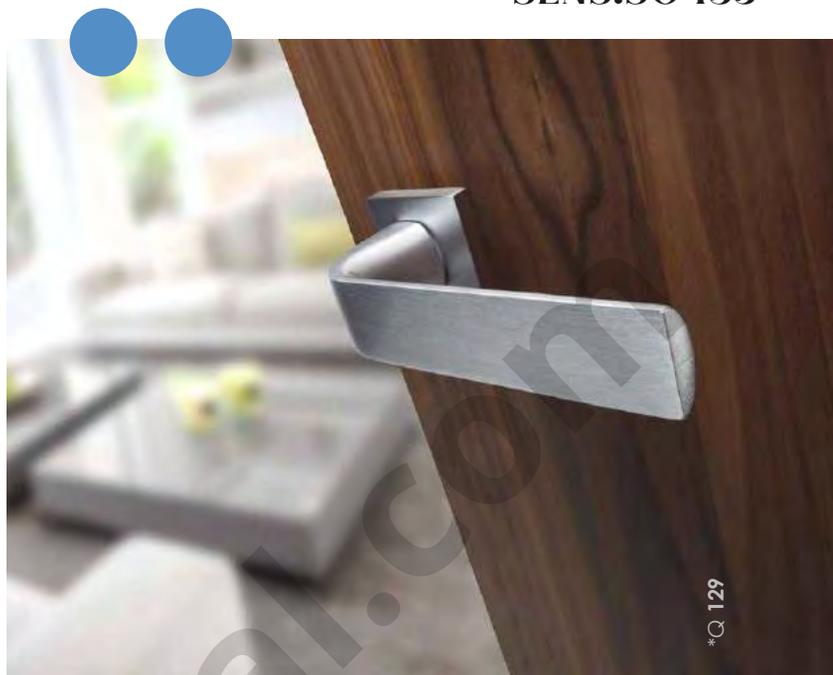

\*Q 129

Rose  
Roseta

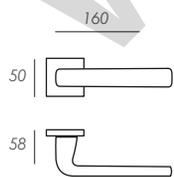

R8C

Narrow Rose  
Roseta Estrecha

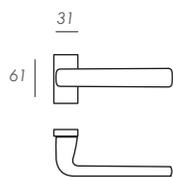

REC

Escutcheon  
Bocallave



R8CBB R8CB

WC Set  
Condensa



R8CCD

Window Handle  
Grisán

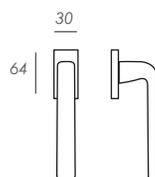

GC

Rectangular Backplate  
Placa Rectangular

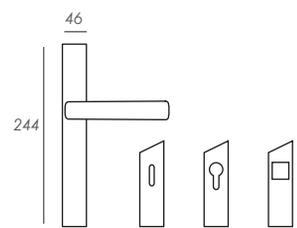

PC PCBB PCB PCCD

# PLANO 137



\*R 57

CR



CR CS



CS



Rose  
Roseta

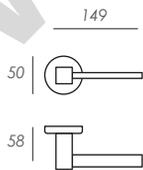

R8

Narrow Rose  
Roseta Estrecha

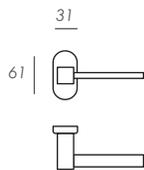

RE

Escutcheon  
Bocallave

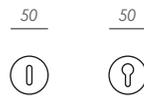

R8BB

R8B

WC Set  
Condena



R8CD

Window Handle  
Grisán

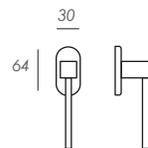

G

Oval Backplate  
Placa Oval

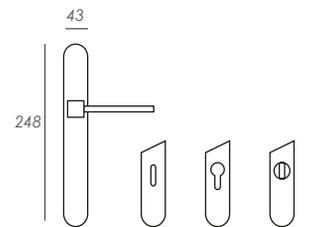

P

PBB

PB

PCD



CR



CR CS



CS



\*Q 131

Rose  
Roseta

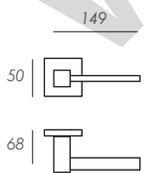

R8C

Narrow Rose  
Roseta Estrecha

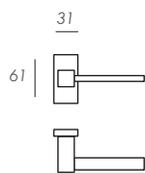

REC

Escutcheon  
Bocallave

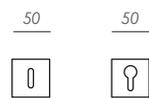

R8CBB

R8CB

WC Set  
Condensa



R8CCD

Window Handle  
Grisán

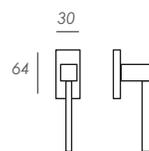

GC

Rectangular Backplate  
Placa Rectangular

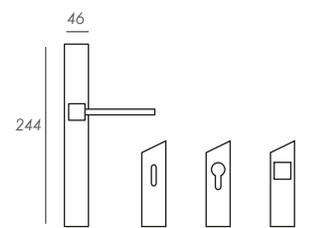

PC

PCBB

PCB

PCCD

# FILA 147

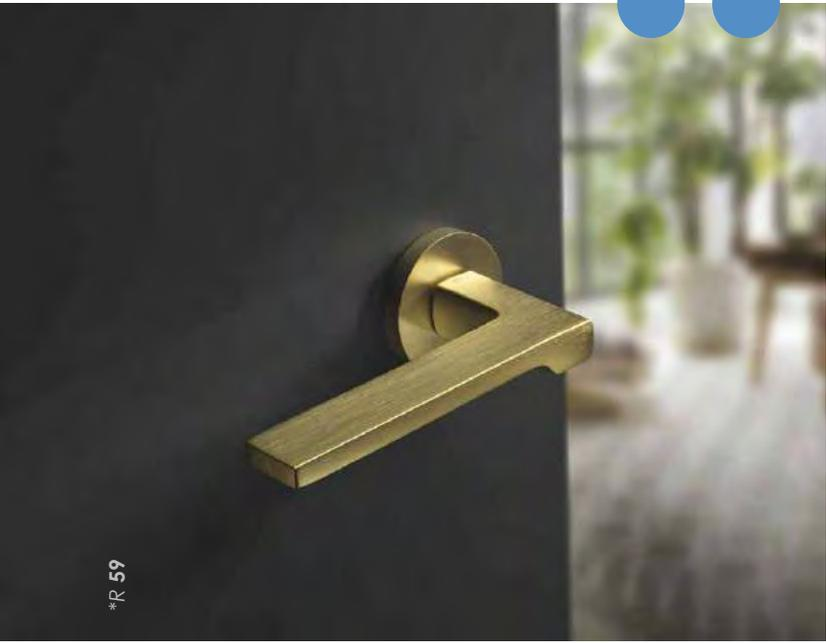

PWLP



PWLS



CR



CS



BK



WT



PWIX



Rose  
Roseta

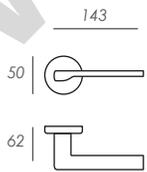

R8

Narrow Rose  
Roseta Estrecha

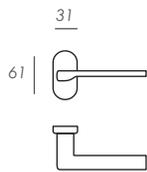

RE

Escutcheon  
Bocallave



R8BB R8B

WC Set  
Condena



R8CD

Window Handle  
Grisán

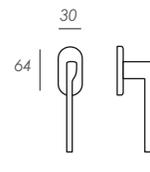

G

Oval Backplate  
Placa Oval

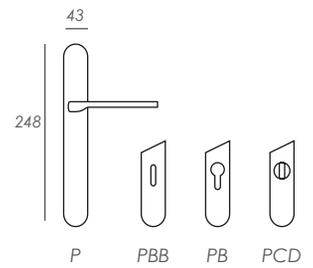



PWLP



PWLS



CR



CS



PWIX



BK



WT

Rose  
Roseta

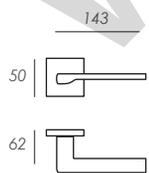

R8C

Narrow Rose  
Roseta Estrecha

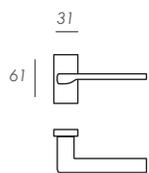

REC

Escutcheon  
Bocallave



R8CBB

R8CB

WC Set  
Condensa



R8CCD

Window Handle  
Grisán

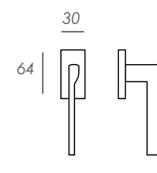

GC

Rectangular Backplate  
Placa Rectangular

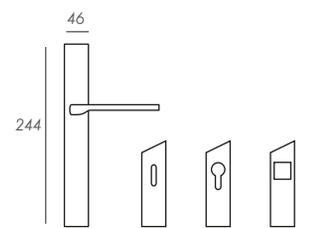

PC

PCBB

PCB

PCCD

# SWIM 157



CR



CS



PWIX



Rose  
Roseta

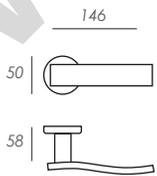

R8

Narrow Rose  
Roseta Estrecha

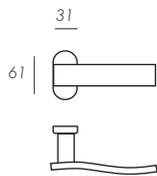

RE

Escutcheon  
Bocallave



R8BB R8B

WC Set  
Condena



R8CD

Window Handle  
Grisán

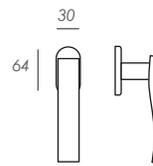

G

Oval Backplate  
Placa Oval

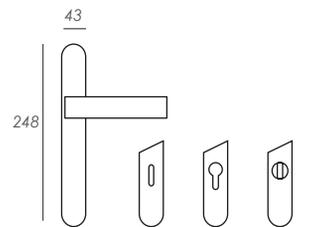

P PBB PB PCD



CR



CS



PWIX

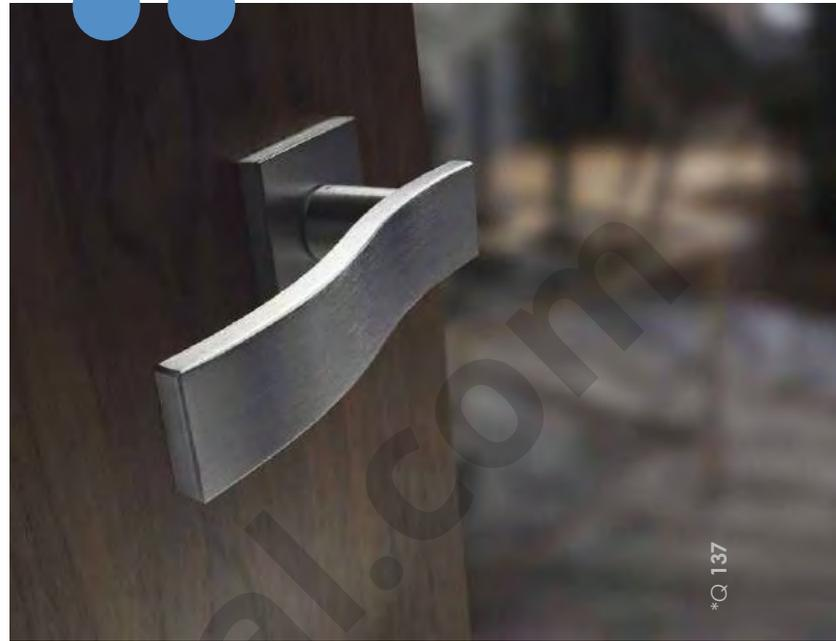

Rose  
Roseta

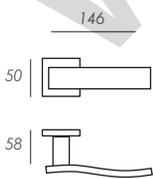

R8C

Narrow Rose  
Roseta Estrecha

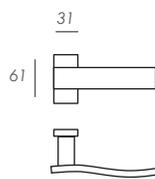

REC

Escutcheon  
Bocallave

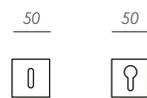

R8CBB

R8CB

WC Set  
Condensa



R8CCD

Window Handle  
Grisán

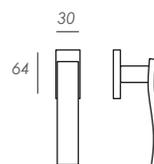

GC

Rectangular Backplate  
Placa Rectangular

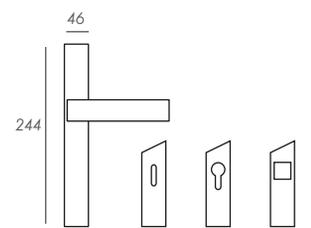

PC

PCBB

PCB

PCCD

NADIA 201







CR CS



CR



CS

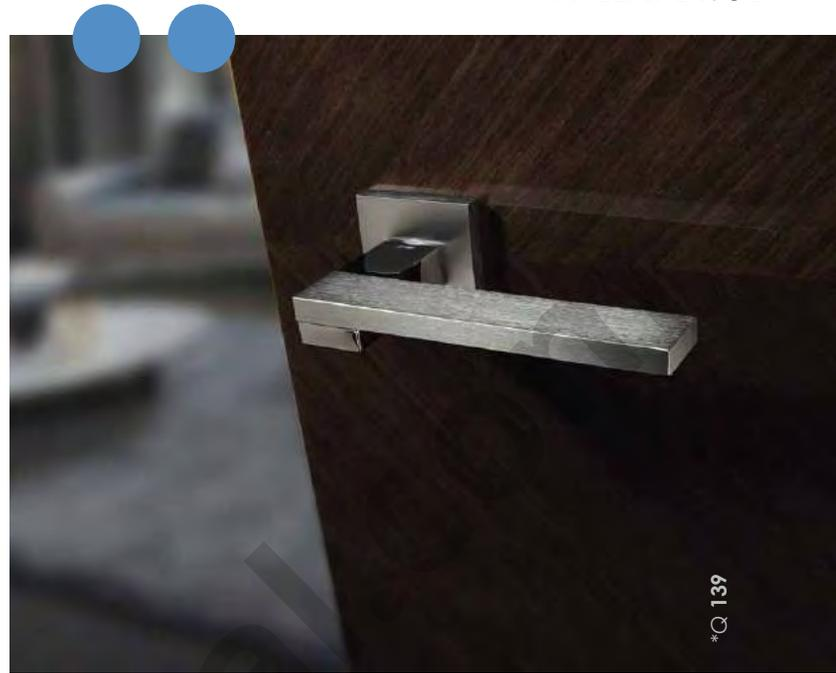

\*Q 139

Rose  
Roseta

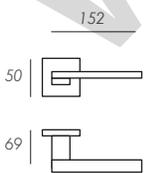

R8C

Narrow Rose  
Roseta Estrecha

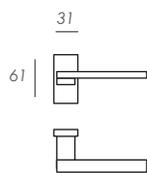

REC

Escutcheon  
Bocallave



R8CBB

R8CB

WC Set  
Condona



R8CCD

Window Handle  
Grisán

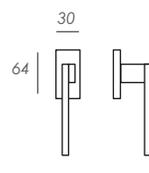

GC

Rectangular Backplate  
Placa Rectangular

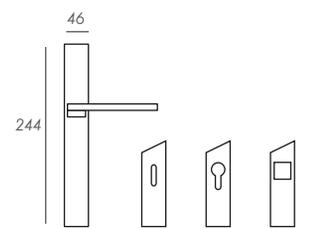

PC

PCBB

PCB

PCCD

# SLIM 204

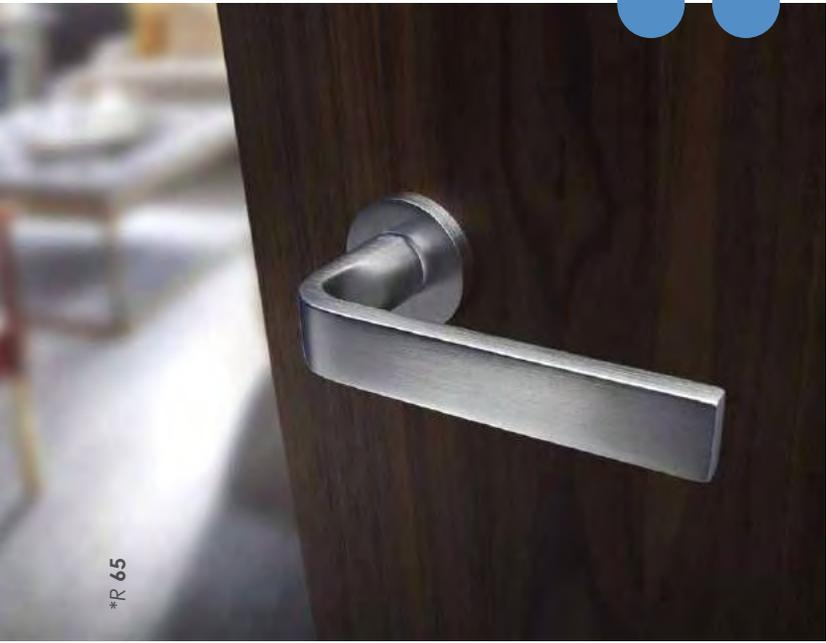

CR



CS



Rose  
Roseta

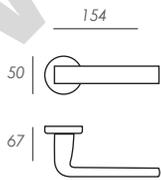

R8

Narrow Rose  
Roseta Estrecha

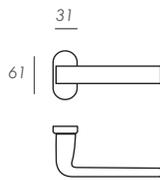

RE

Escutcheon  
Bocallave

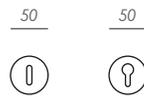

R8BB

R8B

WC Set  
Condena



R8CD

Window Handle  
Grisán

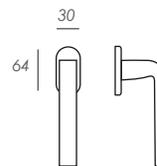

G

Oval Backplate  
Placa Oval

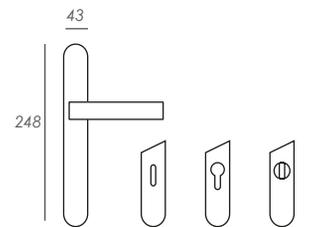

P

PBB

PB

PCD



CR



CS

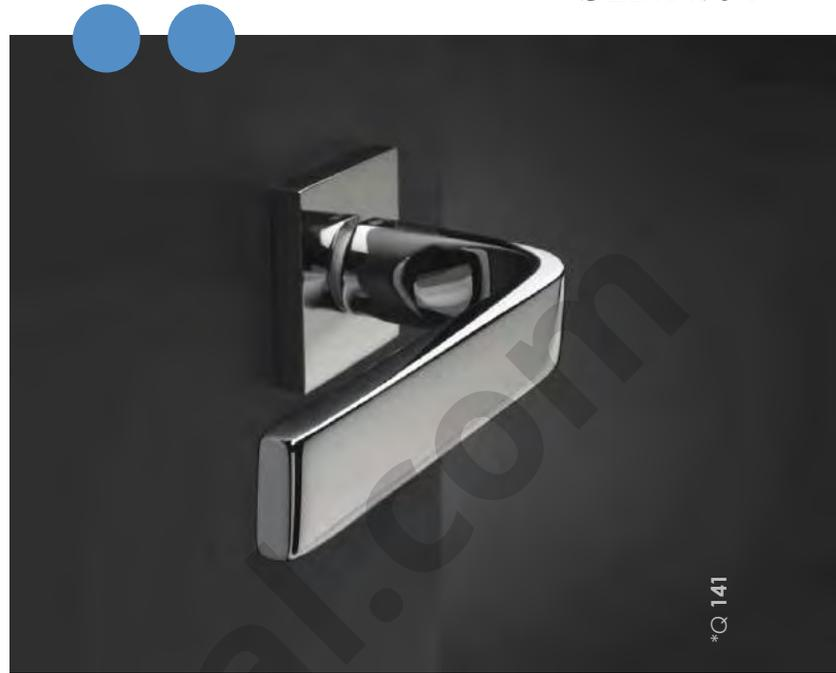

\*Q 141

Rose  
Roseta

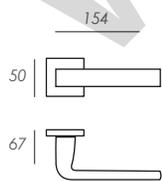

R8C

Narrow Rose  
Roseta Estrecha

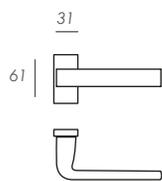

REC

Escutcheon  
Bocallave

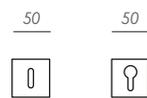

R8CBB R8CB

WC Set  
Condensa



R8CCD

Window Handle  
Grisán

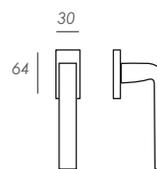

GC

Rectangular Backplate  
Placa Rectangular

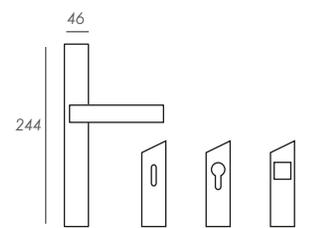

PC PCBB PCB PCCD

STRIP 213



# STRIP 213



CR



CS



PWIX



\*Q 143

Rose  
Roseta

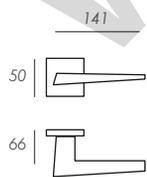

R8C

Narrow Rose  
Roseta Estrecha

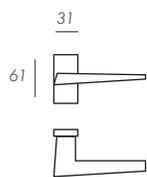

REC

Escutcheon  
Bocallave

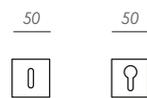

R8CBB R8CB

WC Set  
Condena



R8CCD

Window Handle  
Grisán

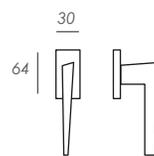

GC

Rectangular Backplate  
Placa Rectangular

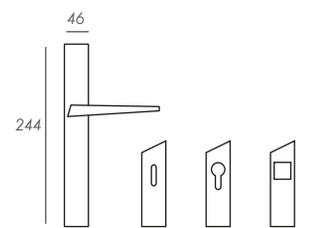

PC PCBB PCB PCCD

# TENDENZA 214



\*R 67

PWLP



PWLS

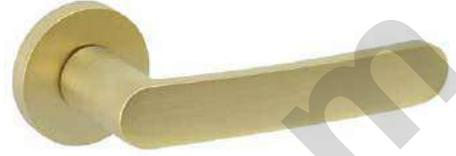

CR



CS



PWGT



BK



PWIX



Rose  
Roseta

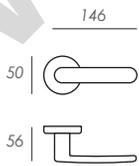

R8

Narrow Rose  
Roseta Estrecha

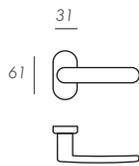

RE

Escutcheon  
Bocallave



R8BB R8B

WC Set  
Condena



R8CD

Window Handle  
Grisán

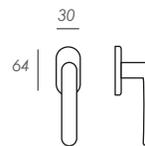

G

Oval Backplate  
Placa Oval

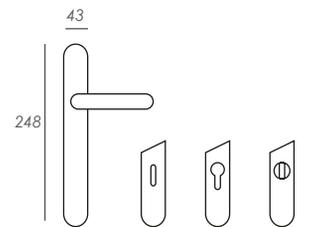

P PBB PB PCD

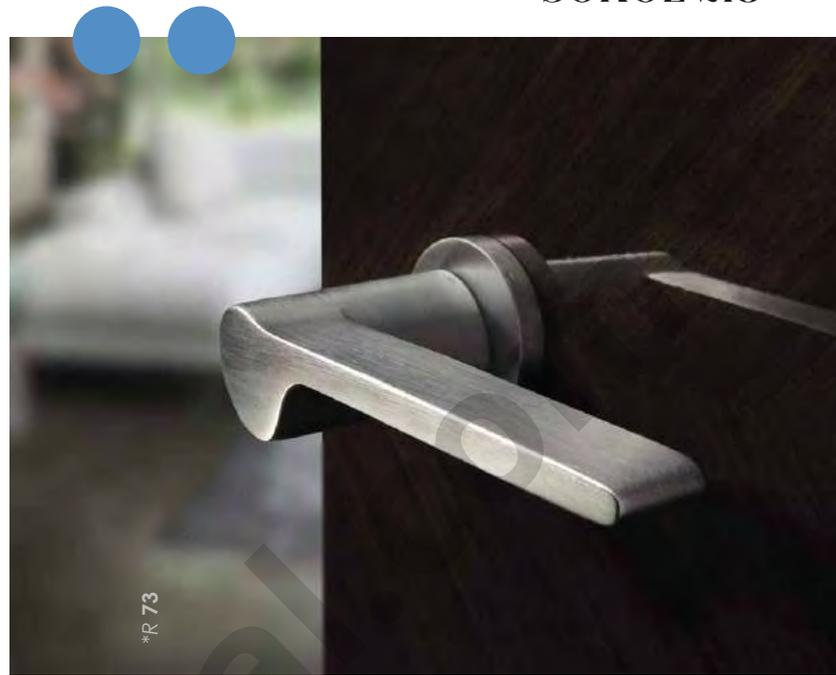

Rose  
Roseta

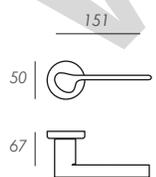

R8

Narrow Rose  
Roseta Estrecha

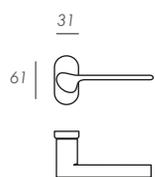

RE

Escutcheon  
Bocallave



R8BB

R8B

WC Set  
Condena



R8CD

Window Handle  
Grisán

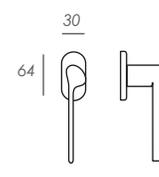

G

Oval Backplate  
Placa Oval

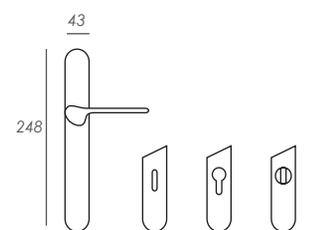

P

PBB

PB

PCD

# VOL.LA 219



CR



CS



MR



Rose  
Roseta

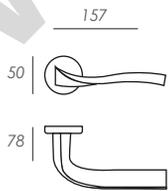

R8

Narrow Rose  
Roseta Estrecha

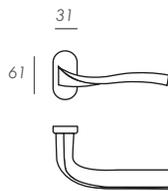

RE

Escutcheon  
Bocallave



R8BB R8B

WC Set  
Condena



R8CD

Window Handle  
Grisán

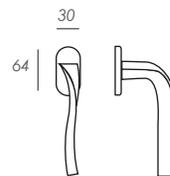

G

Oval Backplate  
Placa Oval

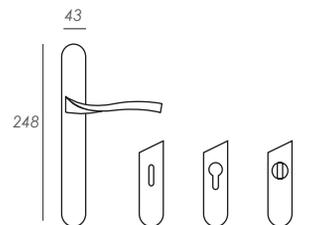

P PBB PB PCD





Rose  
Roseta

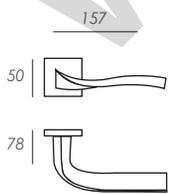

R8C

Narrow Rose  
Roseta Estrecha

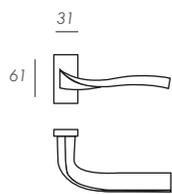

REC

Escutcheon  
Bocallave

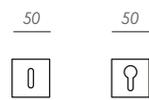

R8CBB

R8CB

WC Set  
Condena



R8CCD

Window Handle  
Grisán

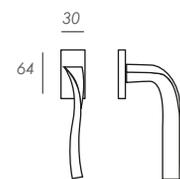

GC

Rectangular Backplate  
Placa Rectangular

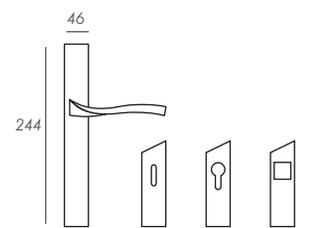

PC

PCBB

PCB

PCCD

QUADRA 227

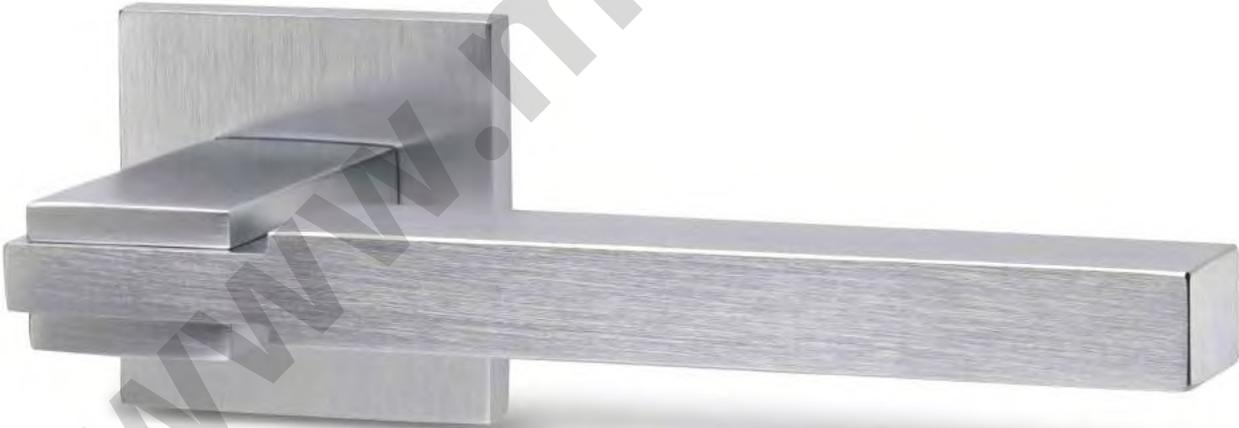

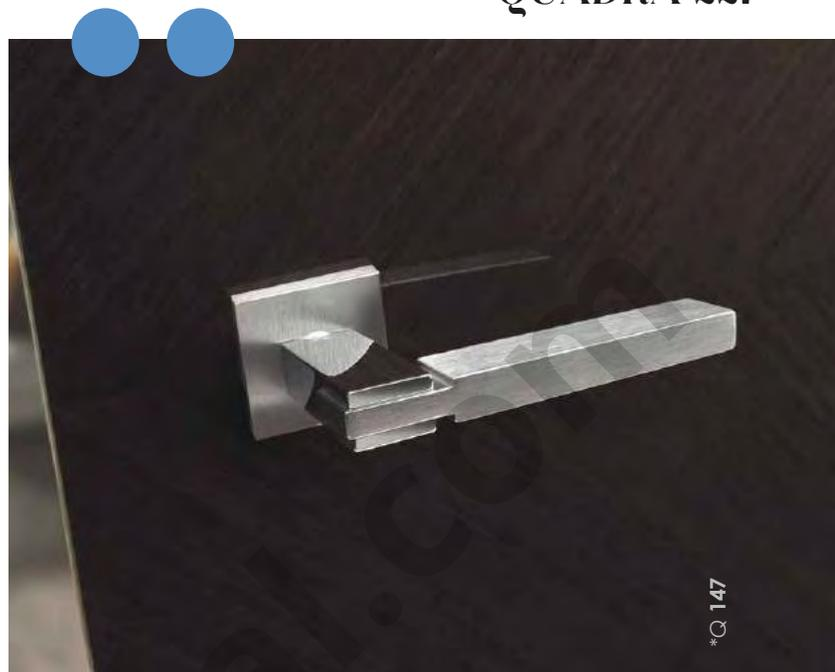
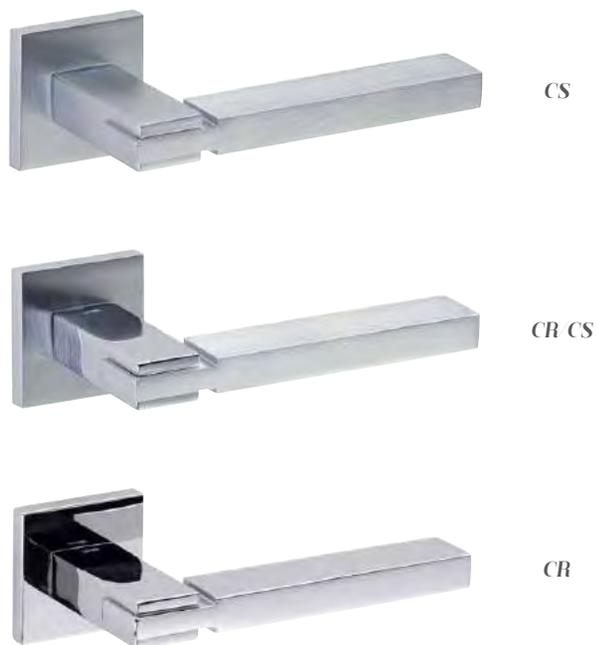

Rose  
Roseta

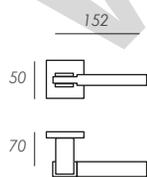

R8C

Narrow Rose  
Roseta Estrecha

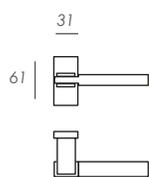

REC

Escutcheon  
Bocallave



R8CBB

R8CB

WC Set  
Condena



R8CCD

Window Handle  
Grisán

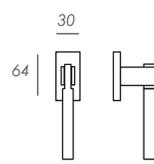

GC

Rectangular Backplate  
Placa Rectangular

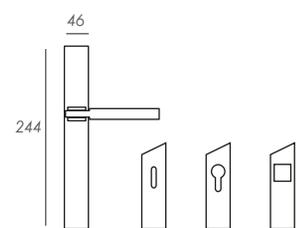

PC

PCBB

PCB

PCCD

# PIN 232

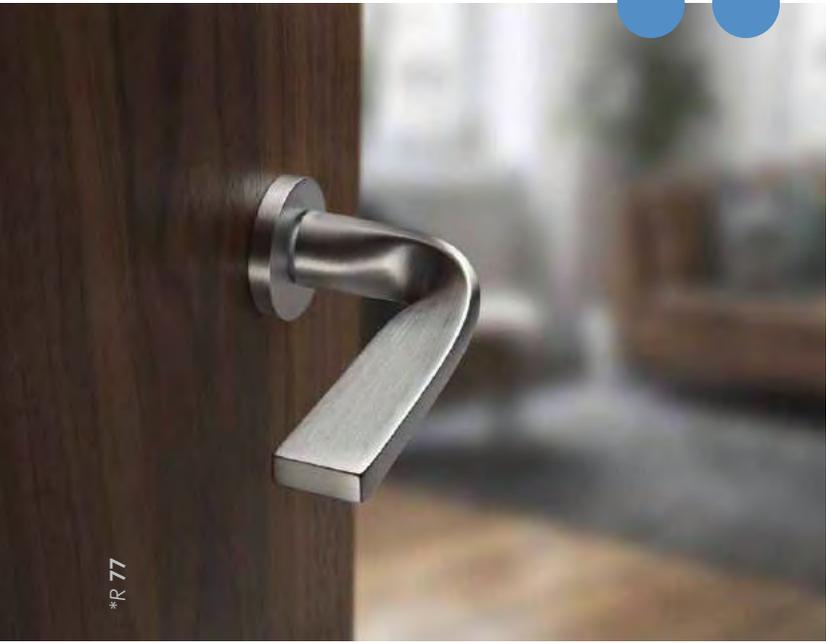

\*R 77

CR



CS



Rose  
Roseta

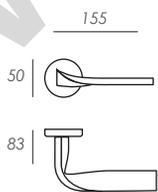

R8

Narrow Rose  
Roseta Estrecha

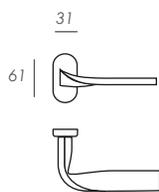

RE

Escutcheon  
Bocallave



R8BB

R8B

WC Set  
Condena



R8CD

Window Handle  
Grisán

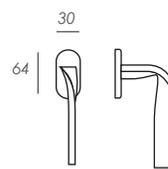

G

Oval Backplate  
Placa Oval

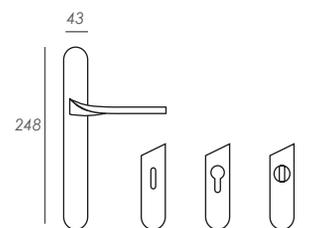

P

PBB

PB

PCD

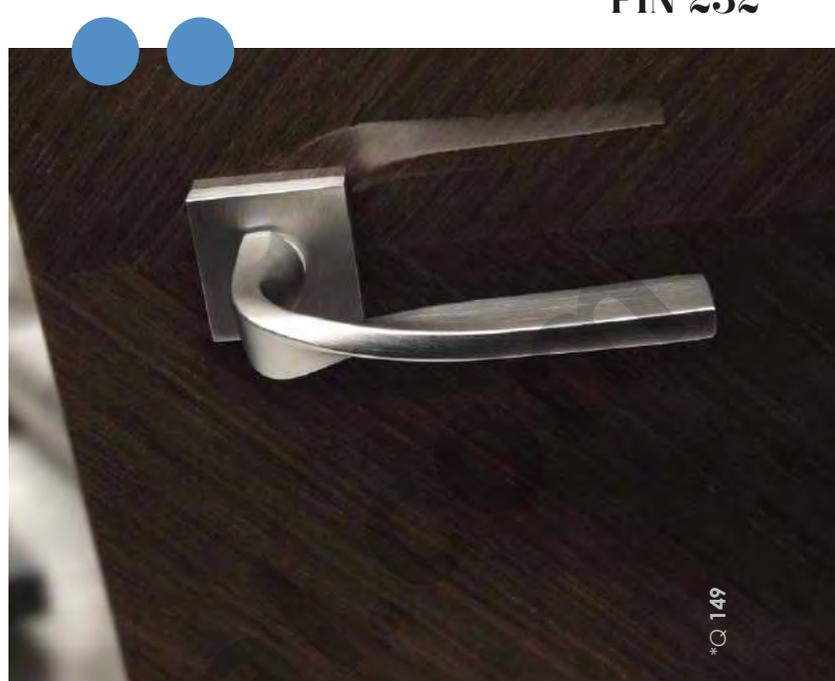

Rose  
Roseta

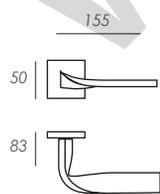

R8C

Narrow Rose  
Roseta Estrecha

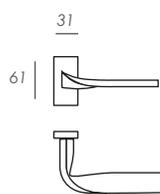

REC

Escutcheon  
Bocallave



R8CBB R8CB

WC Set  
Condensa



R8CCD

Window Handle  
Grisán

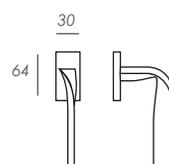

GC

Rectangular Backplate  
Placa Rectangular

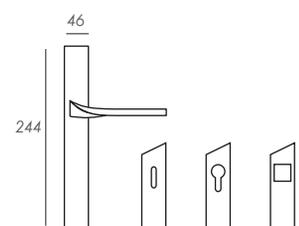

PC PCBB PCB PCCD

# THREE 233



CR



CS



Rose  
Roseta

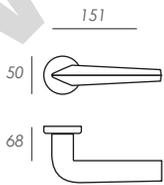

R8

Narrow Rose  
Roseta Estrecha

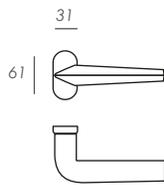

RE

Escutcheon  
Bocallave



R8BB R8B

WC Set  
Condena



R8CD

Window Handle  
Grisán

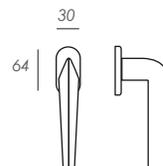

G

Oval Backplate  
Placa Oval

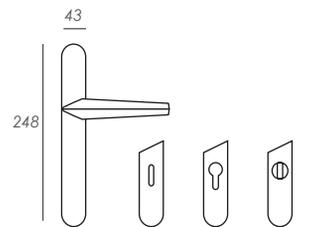

P PBB PB PCD



CR



CS



\*Q 151

Rose  
Roseta

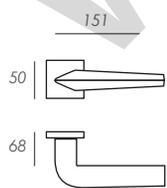

R8C

Narrow Rose  
Roseta Estrecha

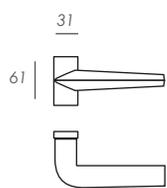

REC

Escutcheon  
Bocallave



R8CBB

R8CB

WC Set  
Condensa



R8CCD

Window Handle  
Grisán

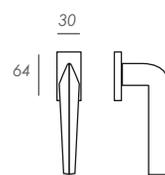

GC

Rectangular Backplate  
Placa Rectangular

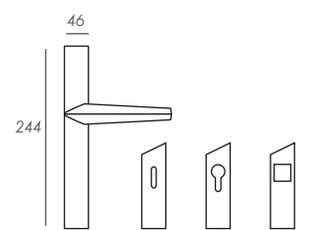

PC

PCBB

PCB

PCCD

# FLOW 237

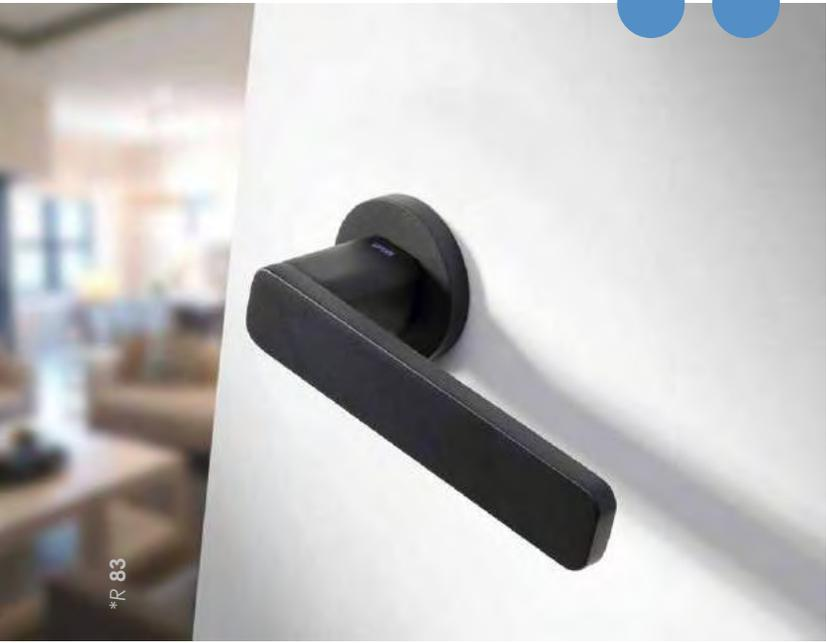

PWLS



CR



CS



PWIX



PWGT



Rose  
Roseta

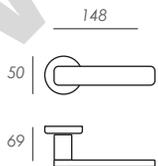

R8

Narrow Rose  
Roseta Estrecha

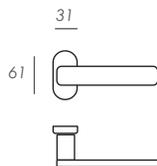

RE

Escutcheon  
Bocallave

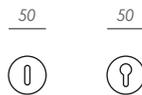

R8BB R8B

WC Set  
Condena



R8CD

Window Handle  
Grisán

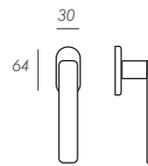

G

Oval Backplate  
Placa Oval

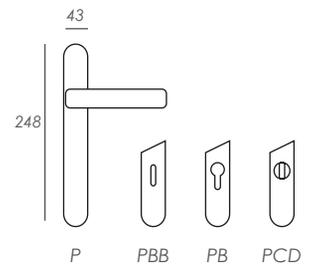

P PBB PB PCD



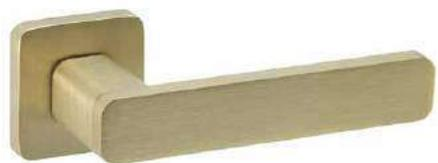

PWLS



CR



CS



PWIX



PWGT

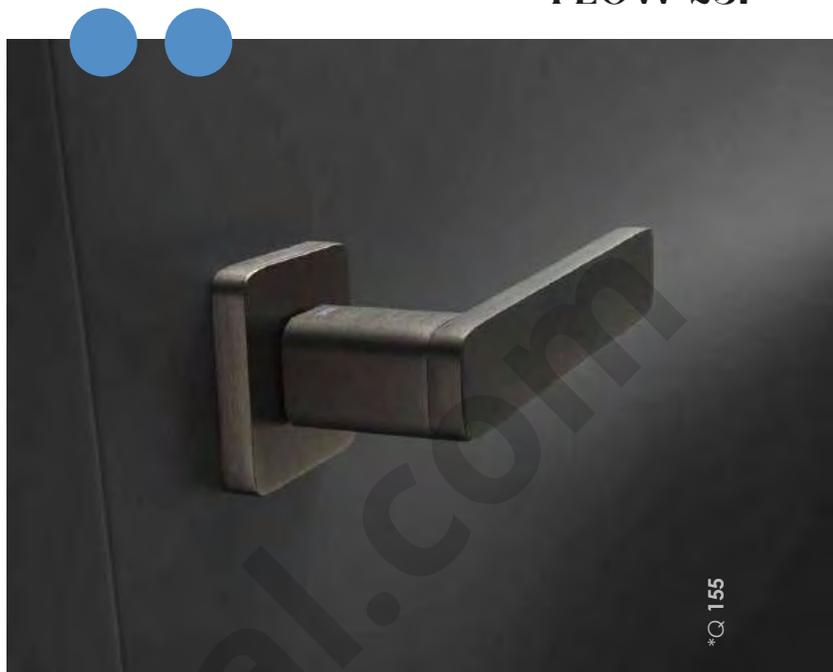

\*Q 155

Rose  
Roseta

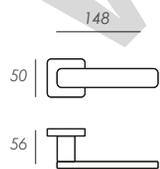

R4C

Narrow Rose  
Roseta Estrecha

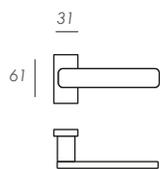

REC

Escutcheon  
Bocallave



R4CBB

R4CB

WC Set  
Condensa



R4CCD

Window Handle  
Grisán

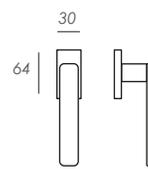

GC

Rectangular Backplate  
Placa Rectangular

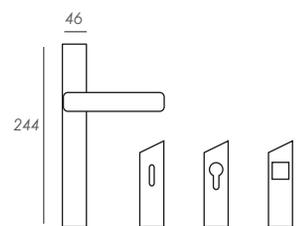

PC

PCBB

PCB

PCCD

# SPECIAL 247



\*R 85

PWLP



PWLS



CR



CS



PWGT



BK



PWIX



Rose  
Roseta

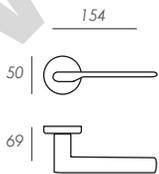

R8

Narrow Rose  
Roseta Estrecha

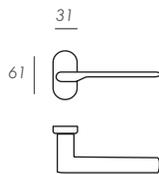

RE

Escutcheon  
Bocallave

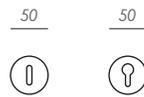

R8BB R8B

WC Set  
Condena



R8CD

Window Handle  
Grisán

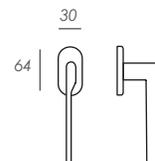

G

Oval Backplate  
Placa Oval

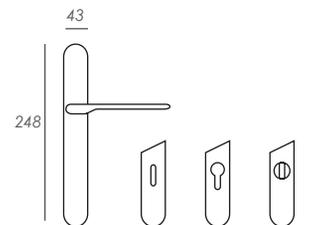

P PBB PB PCD

# SPECIAL 247



PWLP



PWLS



CR



CS



PWIX



PWGT



BK

Rose  
Roseta

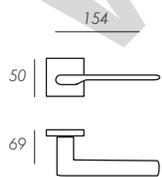

R8C

Narrow Rose  
Roseta Estrecha

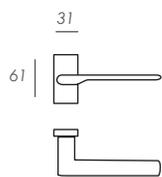

REC

Escutcheon  
Bocallave

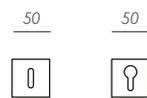

R8CBB

R8CB

WC Set  
Condensa



R8CCD

Window Handle  
Grisán

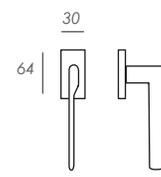

GC

Rectangular Backplate  
Placa Rectangular

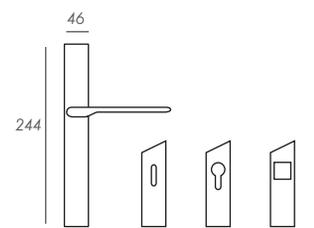

PC

PCBB

PCB

PCCD

# SASHA 255

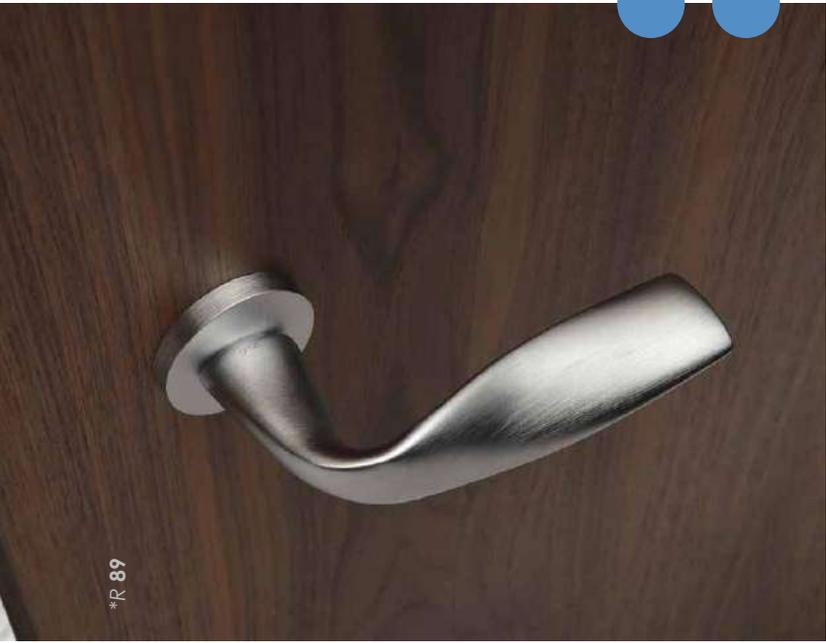

CR



CS



Rose  
Roseta

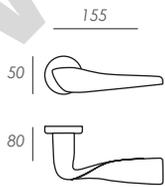

R8

Narrow Rose  
Roseta Estrecha

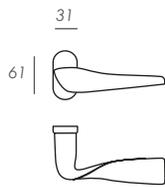

RE

Escutcheon  
Bocallave



R8BB

R8B

WC Set  
Condena



R8CD

Window Handle  
Grisán

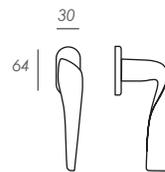

G

Oval Backplate  
Placa Oval

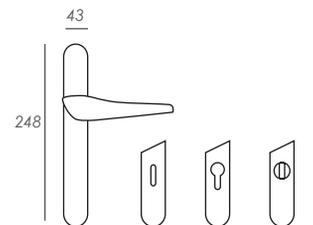

P

PBB

PB

PCD

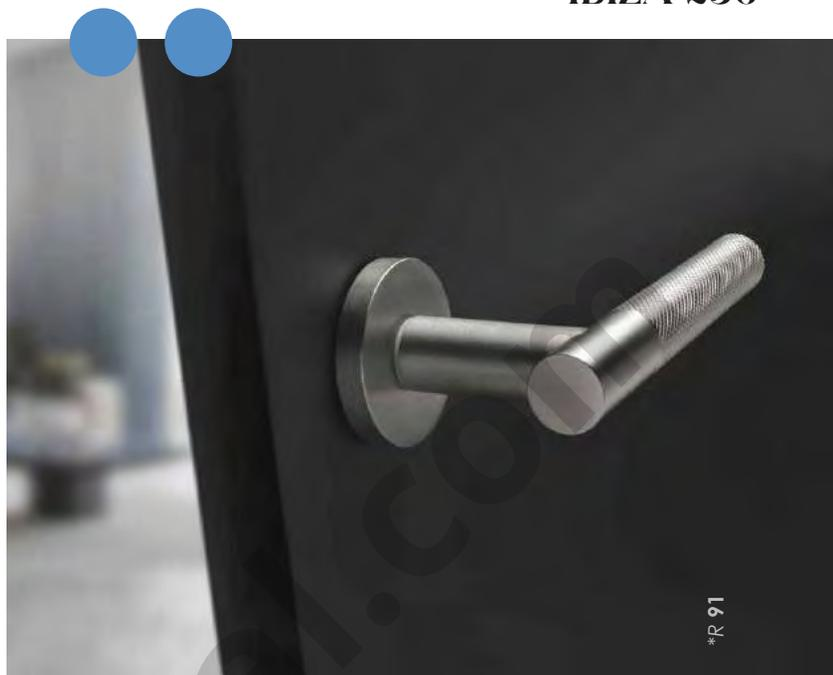

Rose  
Roseta

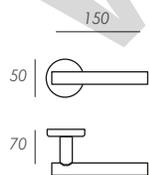

R8

Narrow Rose  
Roseta Estrecha

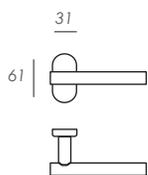

RE

Escutcheon  
Bocallave



R8BB

R8B

WC Set  
Condena



R8CD6

Window Handle  
Grisán

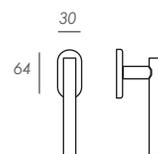

G

Oval Backplate  
Placa Oval

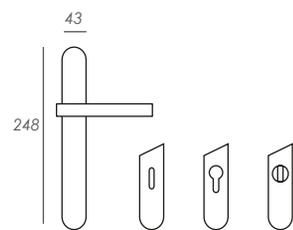

P

PBB

PB

PCD

# TROMBETTA 510



R3 PWLP



R3 PWNB



R8 PWLP



R8 PWNB



Rose  
Roseta

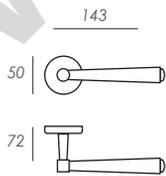

R3  
R8

Narrow Rose  
Roseta Estrecha

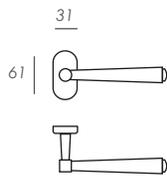

RE

Escutcheon  
Bocallave

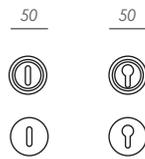

R3BB  
R8BB    R3B  
R8B

WC Set  
Condena

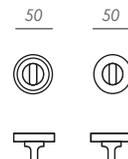

R3CD  
R8CD

Window Handle  
Grisán

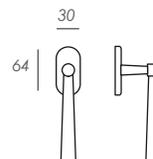

G

Oval Backplate  
Placa Oval

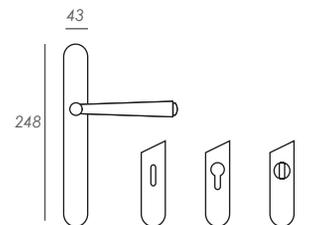

P    PBB    PB    PCD



R3 PWLP



R3 PWNB



R8 PWLP



R8 PWNB



R8 OB



Rose  
Roseta

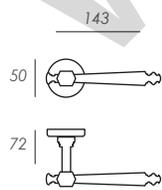

R3  
R8

Narrow Rose  
Roseta Estrecha

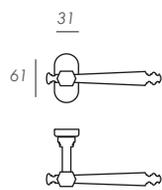

RE

Escutcheon  
Bocallave

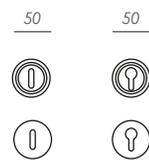

R3BB  
R8BB      R3B  
R8B

WC Set  
Condena

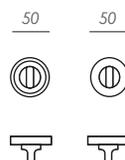

R3CD  
R8CD

Window Handle  
Grisán

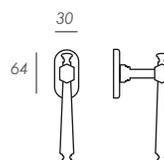

G

Oval Backplate  
Placa Oval

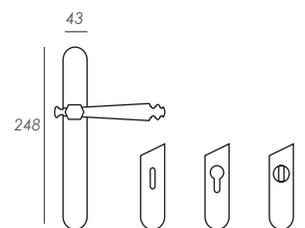

P      PBB      PB      PCD

# OTTO 528



\*Q 179

R18 LP



R18 CR



R18 BO



Rose  
Roseta

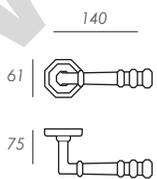

R18

Narrow Rose  
Roseta Estrecha

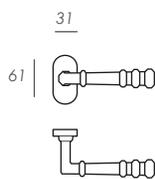

RE

Escutcheon  
Bocallave



R18BB R18B

WC Set  
Condena



R18CD8

Window Handle  
Grisán

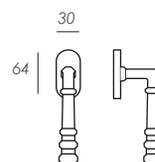

G

Rectangular Backplate  
Placa Rectangular

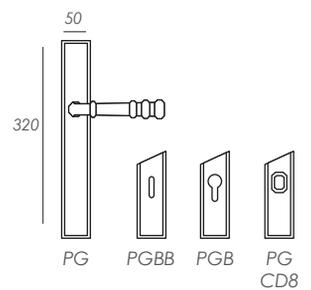



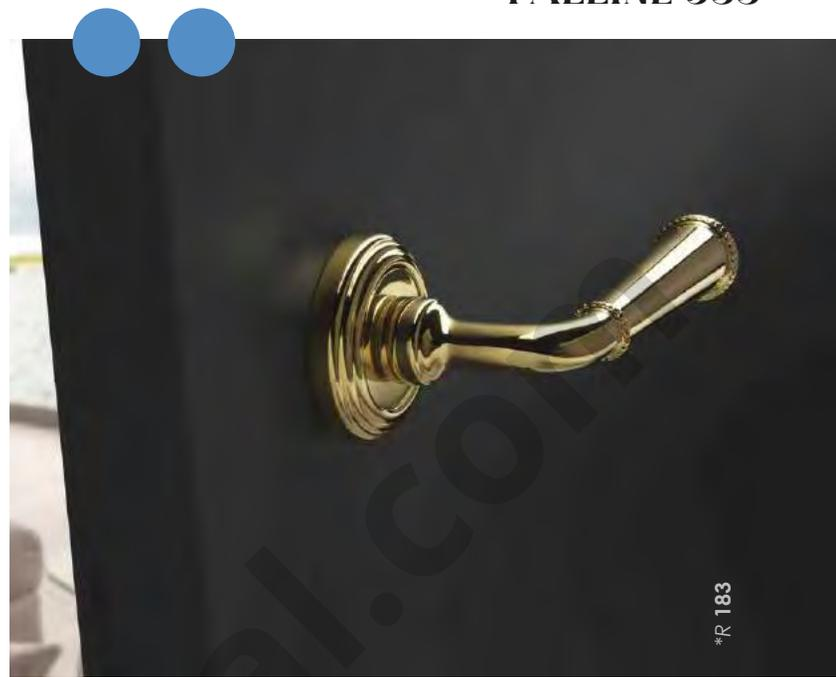

Rose  
Roseta

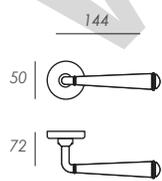

R3

Narrow Rose  
Roseta Estrecha

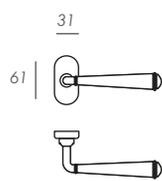

RE

Escutcheon  
Bocallave

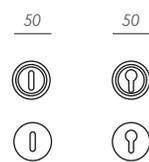

R3BB  
R8BB      R3B  
R8B

WC Set  
Condena

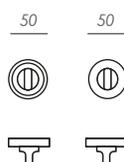

R3CD  
R8CD

Window Handle  
Grisán

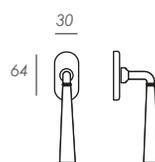

G

Bollines Backplate  
Placa Bollines

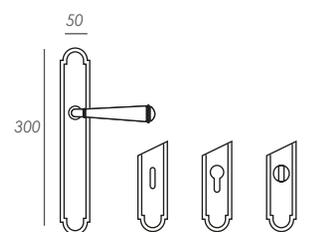

P3      P3BB      P3B      P3CD

# VASILISA 540



R8 PWLP



R8 PWLS



R8 PWNB



R8 BK



R8 PWCO



Rose  
Roseta

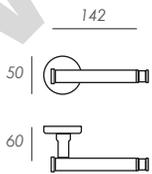

R8

Narrow Rose  
Roseta Estrecha

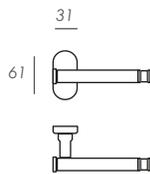

RE

Escutcheon  
Bocallave



R8BB

R8B

WC Set  
Condena



R8CD

Window Handle  
Grisán

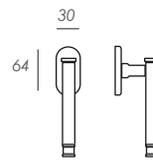

G

Oval Backplate  
Placa Oval

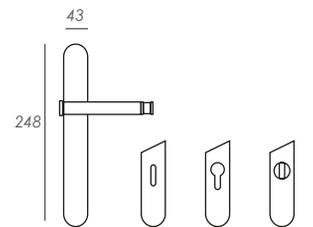

P

PBB

PB

PCD

# ARTDÉCO 550



R3 PWLP



R3 PWNB



R8 PWLP



R8 PWNB



Rose  
Roseta

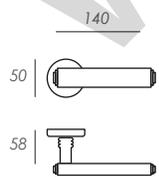

R8

Narrow Rose  
Roseta Estrecha

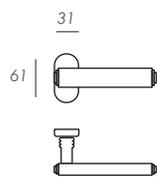

RE

Escutcheon  
Bocallave

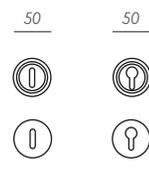

R3BB  
R8BB

R3B  
R8B

WC Set  
Condena

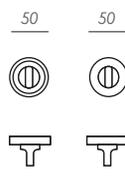

R3CD  
R8CD

Window Handle  
Grisán

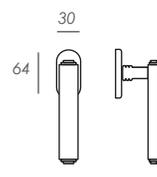

G

Oval Backplate  
Placa Oval

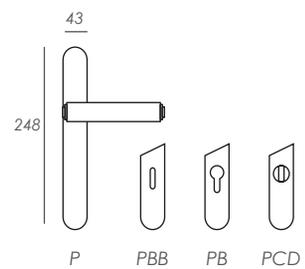

P

PBB

PB

PCD

# NEW YORK 555



\*Q 191

R2 PWNB



R2 PWLP



R2 PWIX



Rose  
Roseta

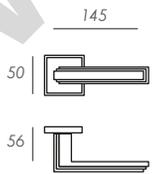

R2C

Narrow Rose  
Roseta Estrecha

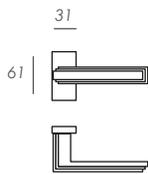

REC

Escutcheon  
Bocallave

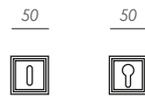

R2CBB R2CB

WC Set  
Condena



R2CCD

Window Handle  
Grisán

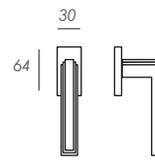

GC

Rectangular Backplate  
Placa Rectangular

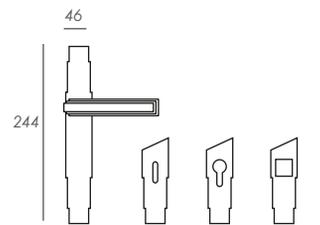

PNY PNYBB PNYB PNYCD



R2C PWLP



R2C PWLS



R2C PWNB



R8C PWLP

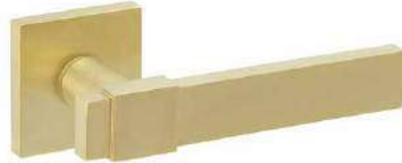

R8C PWLS



R8C PWNB



\*Q 193

Rose  
Roseta

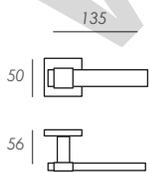

R8C

Narrow Rose  
Roseta Estrecha

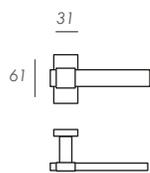

REC

Escutcheon  
Bocallave

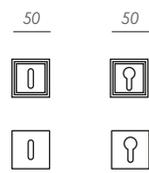

R2CBB  
R8CBB    R2CB  
R8CB

WC Set  
Condensa

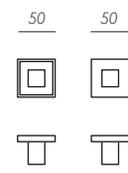

R2CCD  
R8CCD

Window Handle  
Grisán

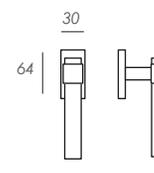

GC

Rectangular Backplate  
Placa Rectangular

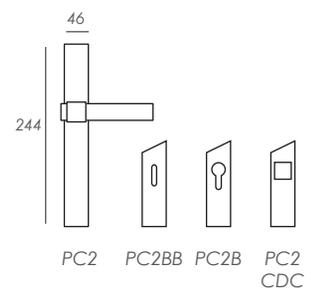

# MALIKA 570



R2C PWLP



R2C PWLS



R2C PWNB



R8C PWLP



R8C PWLS



R8C PWNB



Rose  
Roseta

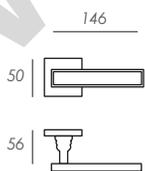

R2C  
R8C

Narrow Rose  
Roseta Estrecha

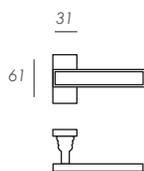

REC

Escutcheon  
Bocallave

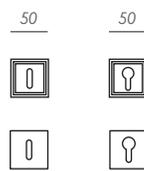

R2CBB  
R8CBB

WC Set  
Condena

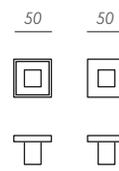

R2CCD  
R8CCD

Window Handle  
Grisán

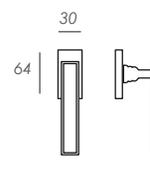

GC

Rectangular Backplate  
Placa Rectangular

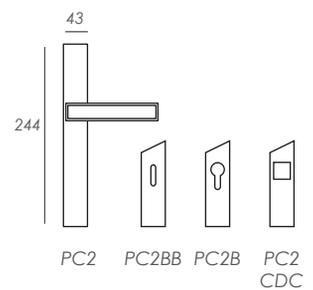

# ELISABETH 580



R3 PWLP



R3 CR



R3 PWNB

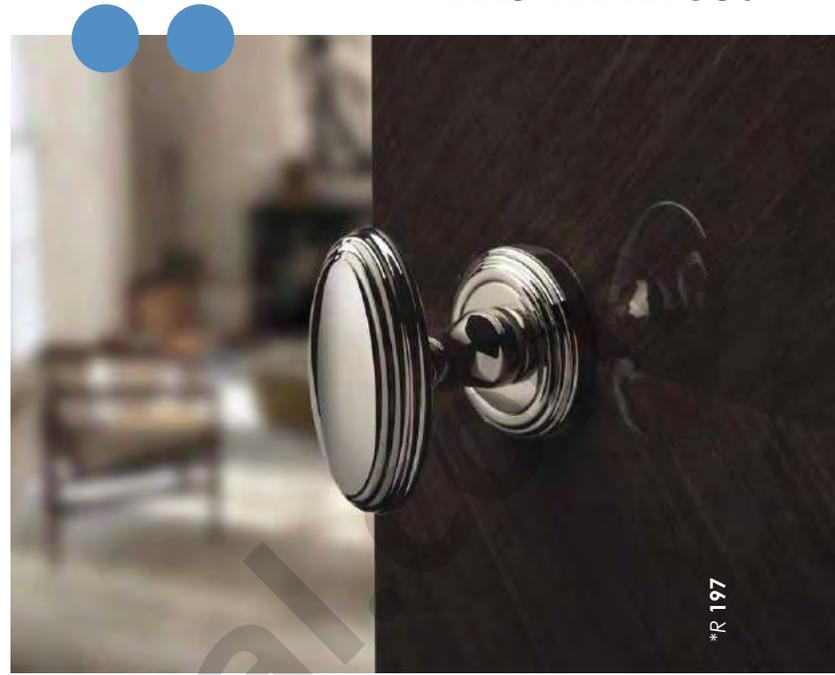

\*R 197

Rose  
Roseta



R3

Narrow Rose  
Roseta Estrecha



RE

Escutcheon  
Bocallave

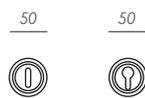

R3BB

R3B

WC Set  
Condena



R3CD

Window Handle  
Grisán



G

Rectangular Backplate  
Placa Rectangular

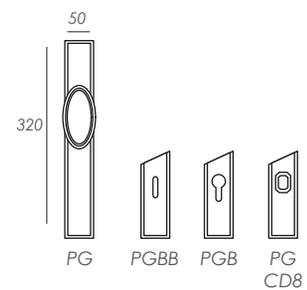

PG

PGBB

PGB

PG CD8

# CHÉRIE 590



\*Q 199

LSB



NB



NS



Rose  
Roseta

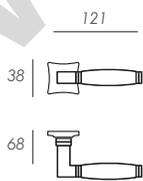

R9

Narrow Rose  
Roseta Estrecha

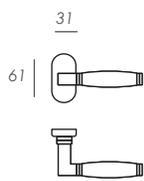

RE

Escutcheon  
Bocallave

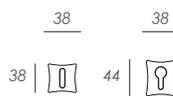

R9BB

R9B

WC Set  
Condena



R9CD

Window Handle  
Grisán

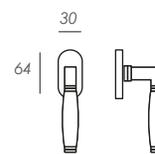

G

Rectangular Backplate  
Placa Rectangular

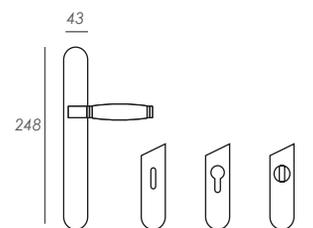

P

PBB

PB

PCD



DOVE 595



CR



LP



Rose  
Roseta

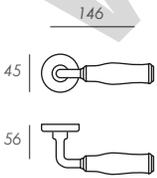

RK

Narrow Rose  
Roseta Estrecha

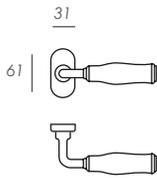

RE

Escutcheon  
Bocallave

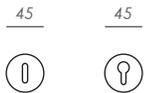

RKBB RKB

WC Set  
Condensa



RKCD

Window Handle  
Grisán

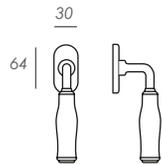

G

Oval Backplate  
Placa Oval

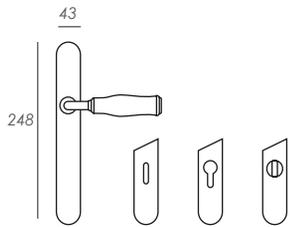

P PBB PB PCD

# ESPUCH 616

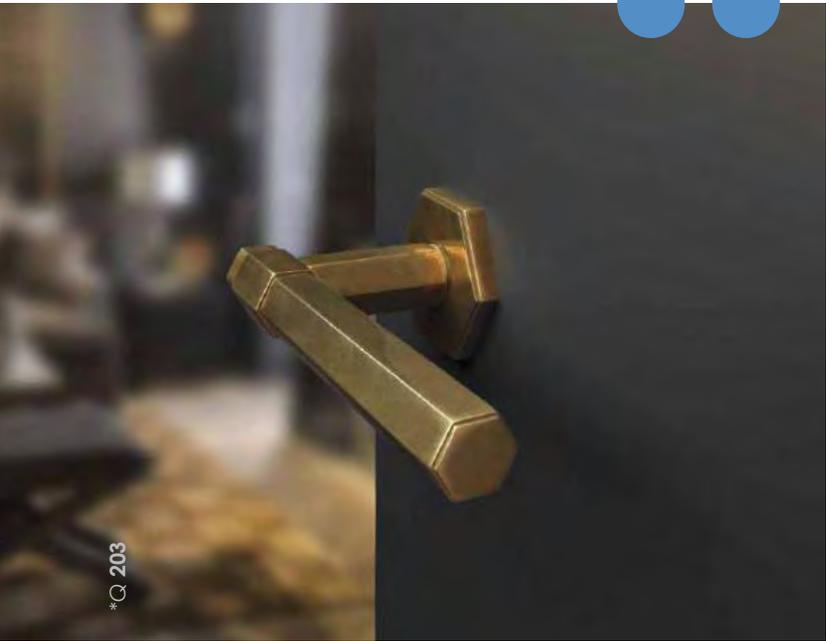

\*C 203

PWLS



PWIX



PWGT



Rose  
Roseta

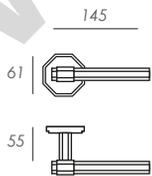

R6C

Narrow Rose  
Roseta Estrecha

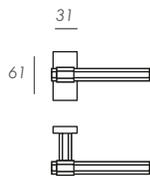

REC

Escutcheon  
Bocallave



R6CBB R6CB

WC Set  
Condena



R6CCD

Window Handle  
Grisán

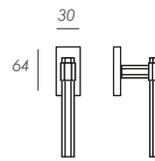

GC

Rectangular Backplate  
Placa Rectangular

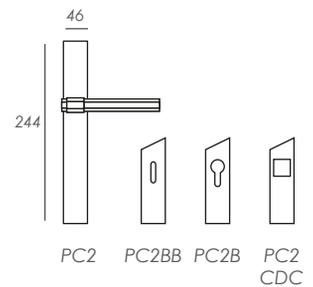

PC2 PC2BB PC2B PC2 CDC



LP



AQ



BO



FU



HI



\*R 209

Rose  
Roseta

Narrow Rose  
Roseta Estrecha

Escutcheon  
Bocallave

WC Set  
Condena

Window Handle  
Grisán

María Backplate  
Placa María

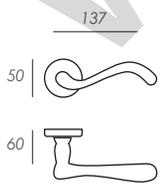

RT

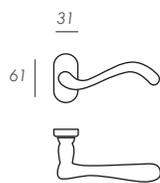

RE

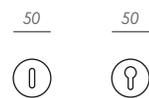

RTBB



RTB



RTCD

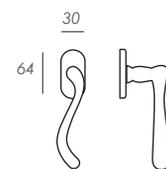

G

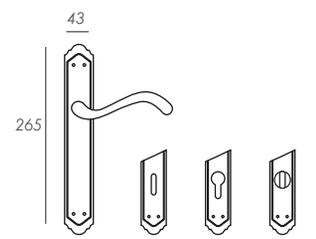

PM

PMBB

PMB

PMCD

# IDEA 804



Rose  
Roseta

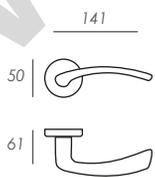

R8

Narrow Rose  
Roseta Estrecha

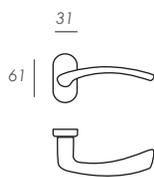

RE

Escutcheon  
Bocallave



R8BB

R8B

WC Set  
Condena



R8CD

Window Handle  
Grisán

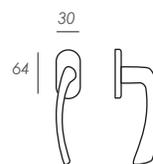

G

Oval Backplate  
Placa Oval

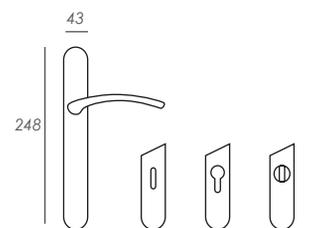

P

PBB

PB

PCD



PWLP



PWLS



CR



CS



PWIX



\*R 97

Rose  
Roseta

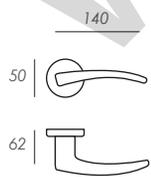

R8

Narrow Rose  
Roseta Estrecha

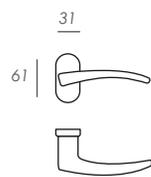

RE

Escutcheon  
Bocallave

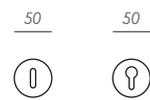

R8BB

R8B

WC Set  
Condensa



R8CD

Window Handle  
Grisán

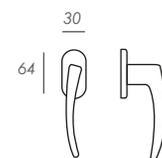

G

Oval Backplate  
Placa Oval

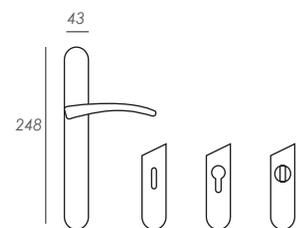

P

PBB

PB

PCD

# SOFT 807

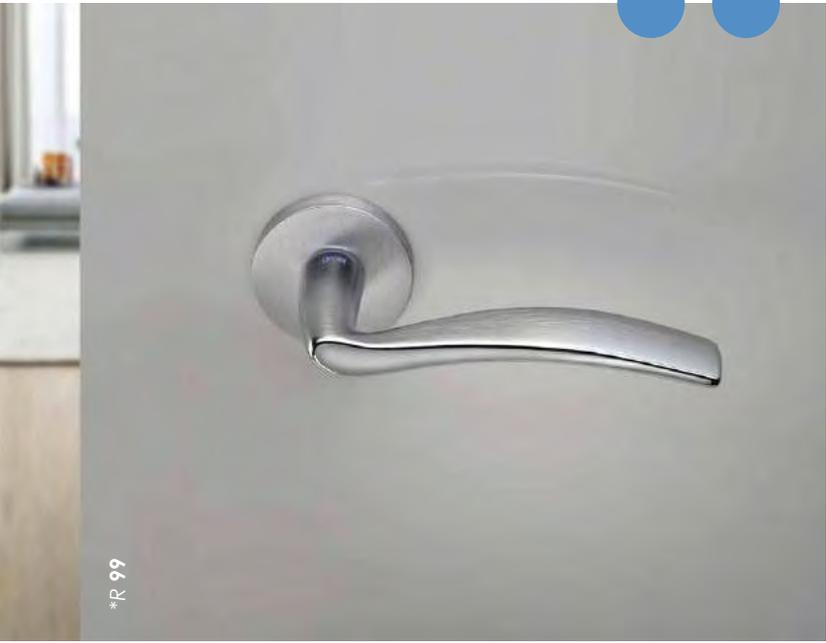

LSLP



CR



CS



CSCR



MRLS



Rose  
Roseta

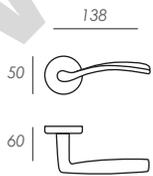

R8

Narrow Rose  
Roseta Estrecha

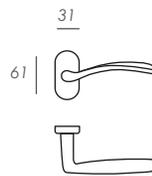

RE

Escutcheon  
Bocallave

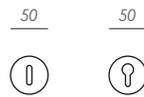

R8BB

R8B

WC Set  
Condena



R8CD

Window Handle  
Grisán

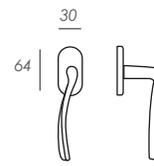

G

Oval Backplate  
Placa Oval

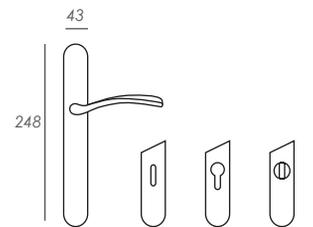

P

PBB

PB

PCD



LPBL



LPMF



MRBL



MRMF

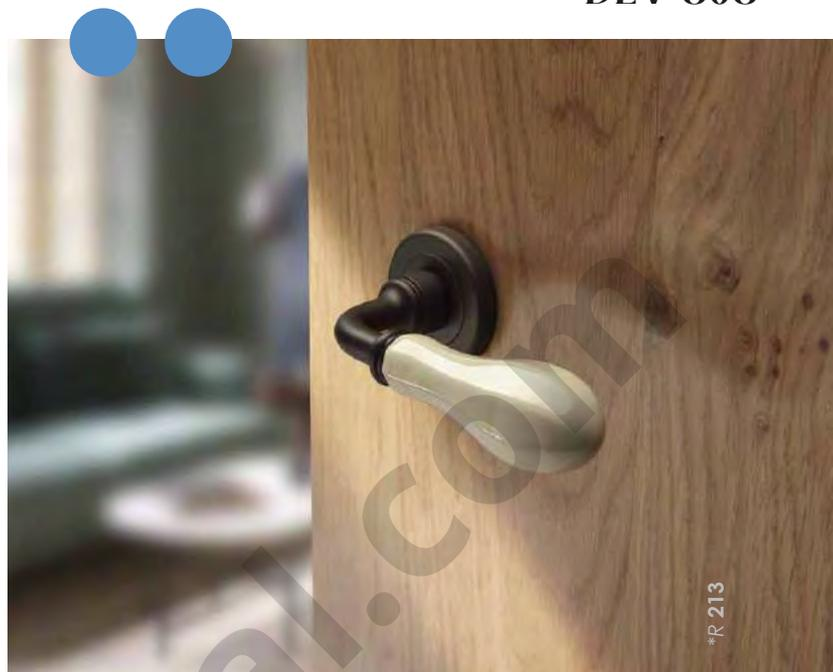

\*R 213

Rose  
Roseta

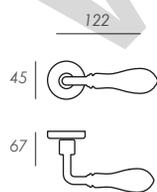

RK

Narrow Rose  
Roseta Estrecha

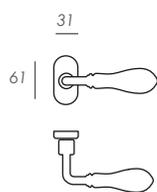

RE

Escutcheon  
Bocallave



RKBB

RKB

WC Set  
Condensa



RKCD

Window Handle  
Grisán

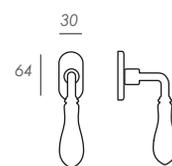

G

Oval Backplate  
Placa Oval

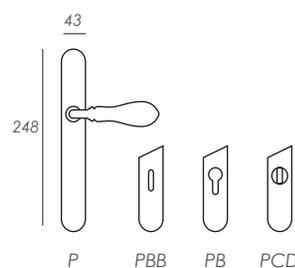

P

PBB

PB

PCD

# KILTO 809

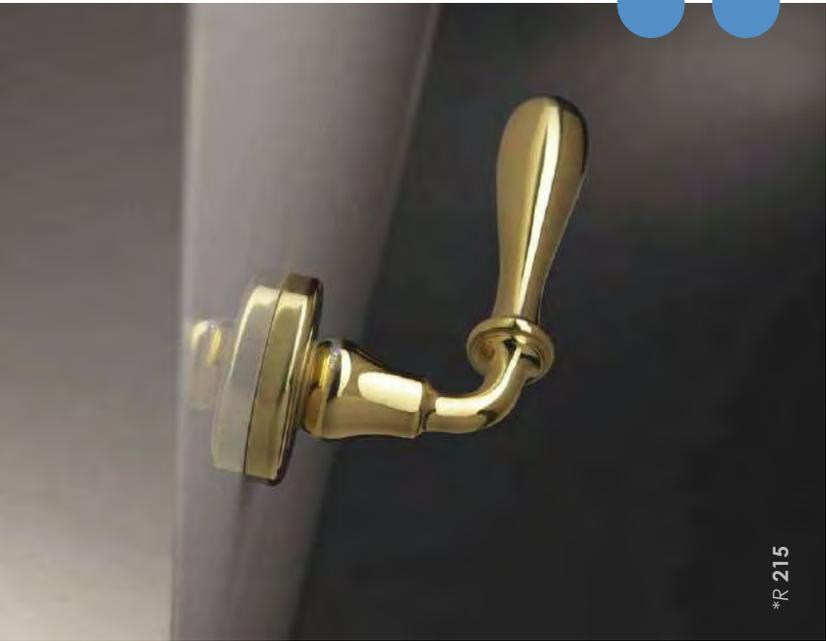

LP



OB



AQ



MR



HI



Rose  
Roseta

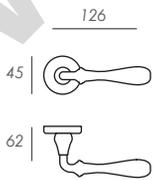

RK

Narrow Rose  
Roseta Estrecha

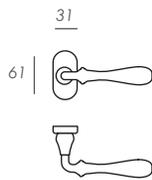

RE

Escutcheon  
Bocallave



RKBB

RKB

WC Set  
Condena



RKCD

Window Handle  
Grisán

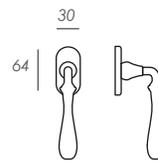

G

Oval Backplate  
Placa Oval

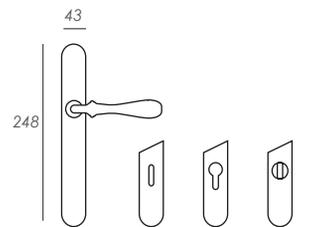

P

PBB

PB

PCD





PWLP



PWLS



CR



CS



PWIX

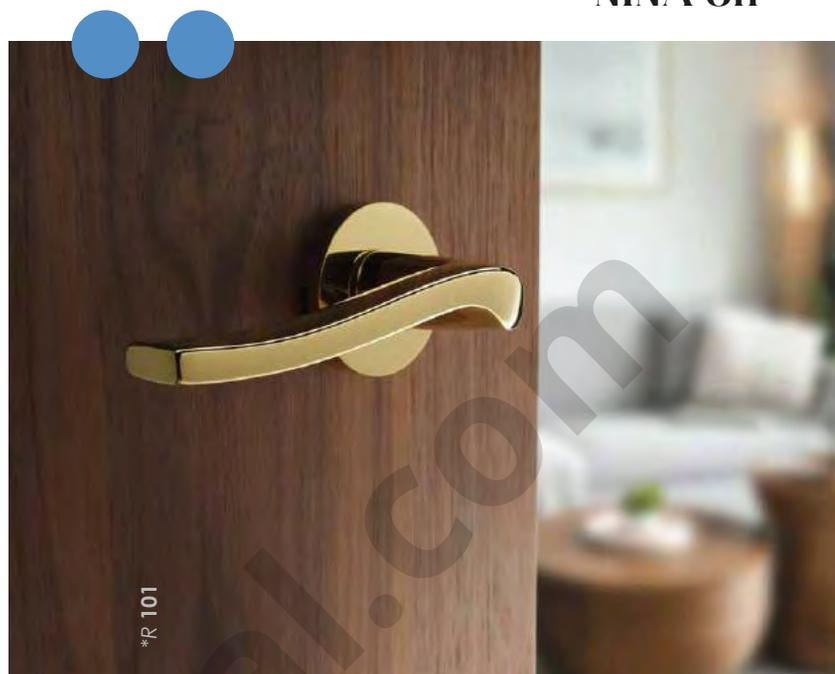

Rose  
Roseta

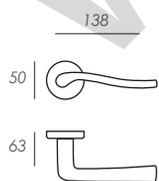

R8

Narrow Rose  
Roseta Estrecha

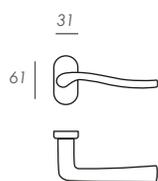

RE

Escutcheon  
Bocallave



R8BB

R8B

WC Set  
Condensa



R8CD

Window Handle  
Grisán

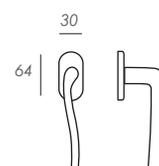

G

Oval Backplate  
Placa Oval

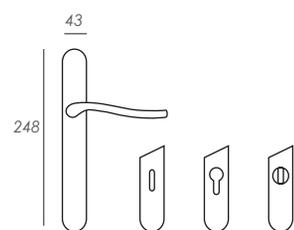

P

PBB

PB

PCD

# ROBY 812



\*R 103

PWLP



PWLS



CR



CS



PWIX



PWGT



BK



WTM



Rose  
Roseta

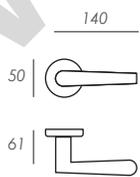

R8

Narrow Rose  
Roseta Estrecha

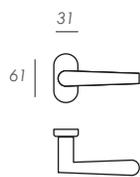

RE

Escutcheon  
Bocallave

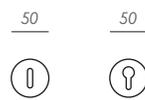

R8BB

R8B

WC Set  
Condena



R8CD

Window Handle  
Grisán

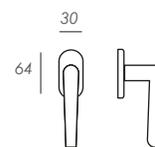

G

Oval Backplate  
Placa Oval

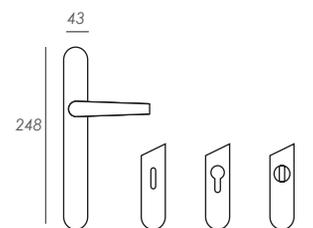

P

PBB

PB

PCD



PWLP



PWLS



CR



CS



PWIX



PWGT



\*R 107



BK



WTM

Rose  
Roseta

Narrow Rose  
Roseta Estrecha

Escutcheon  
Bocallave

WC Set  
Condensa

Window Handle  
Grisán

Oval Backplate  
Placa Oval

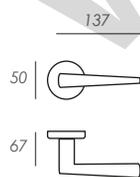

R8

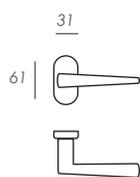

RE



R8BB

R8B



R8CD

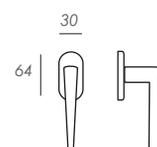

G

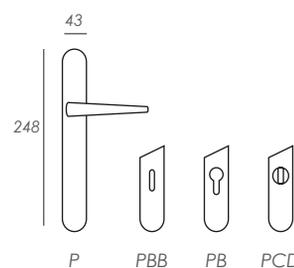

P

PBB

PB

PCD

# BACI 814

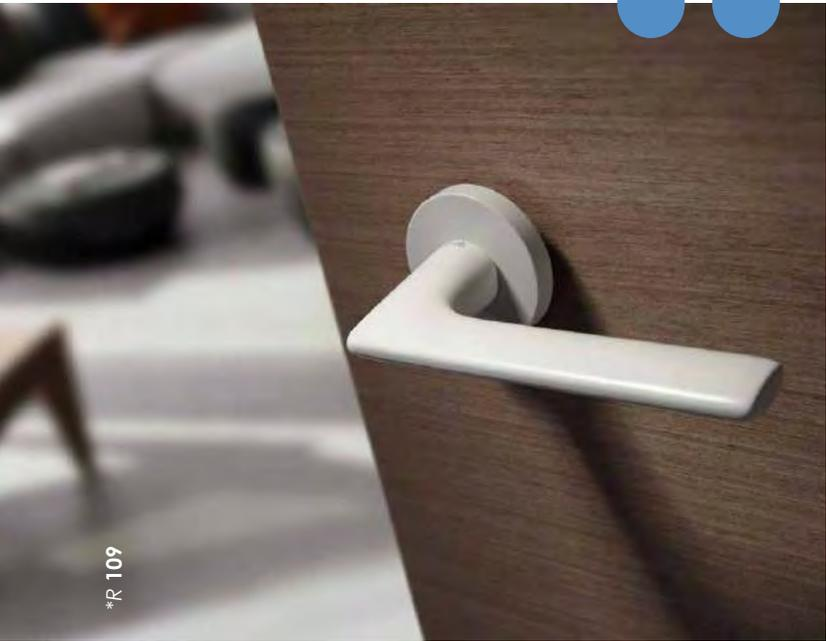

PWLP



PWLS



CR



CS



BK



WTM



PWIX



PWGT



Rose  
Roseta

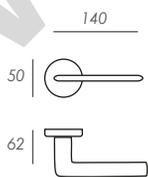

R8

Narrow Rose  
Roseta Estrecha

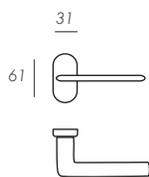

RE

Escutcheon  
Bocallave



R8BB R8B

WC Set  
Condena



R8CD

Window Handle  
Grisán

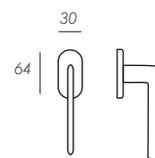

G

Oval Backplate  
Placa Oval

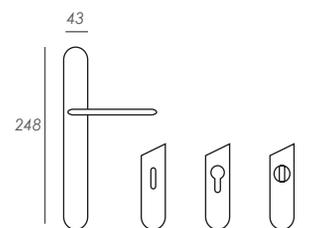

P PBB PB PCD



PWLP



PWLS



CR



CS



PWIX



PWGT



\*Q 163



BK



WTM

Rose  
Roseta

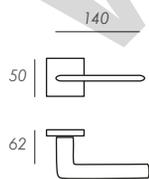

R8C

Narrow Rose  
Roseta Estrecha

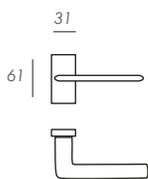

REC

Escutcheon  
Bocallave



R8CBB R8CB

WC Set  
Condensa



R8CCD

Window Handle  
Grisán

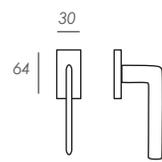

GC

Rectangular Backplate  
Placa Rectangular

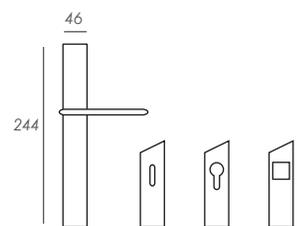

PC PCBB PCB PCCD

# DADÁ 815

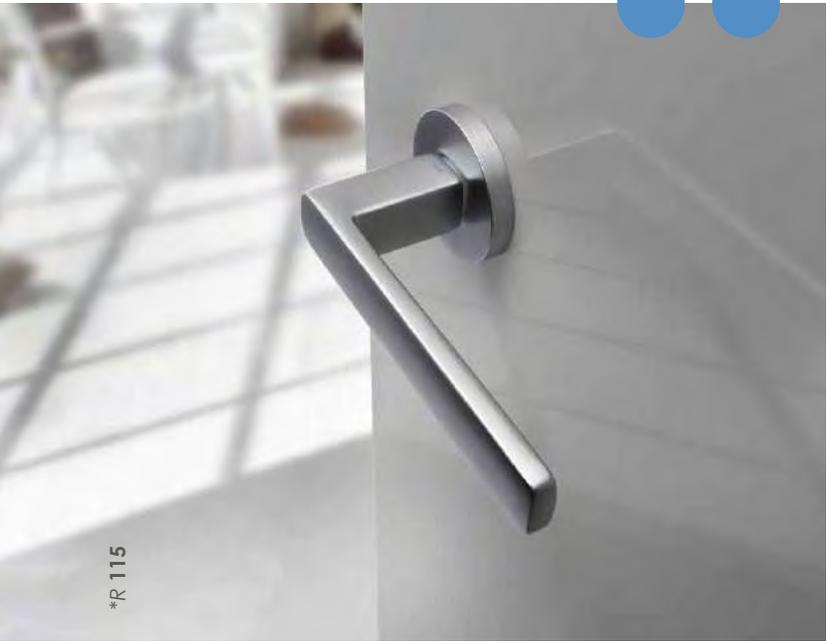

\*R 115

PWLP



PWLS



CR



CS

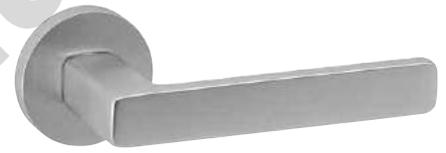

PWIX



PWGT



BK



WTM



Rose  
Roseta

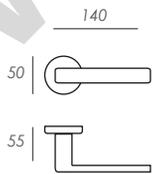

R8

Narrow Rose  
Roseta Estrecha

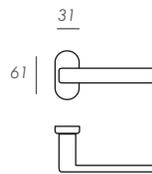

RE

Escutcheon  
Bocallave

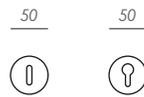

R8BB R8B

WC Set  
Condena



R8CD

Window Handle  
Grisán

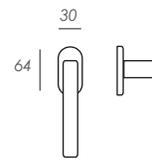

G

Oval Backplate  
Placa Oval

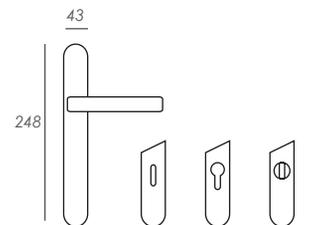

P PBB PB PCD

# DADÁ 815



PWLP

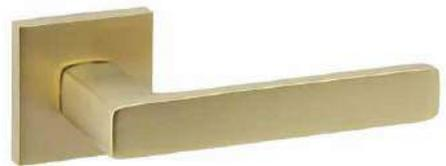

PWLS

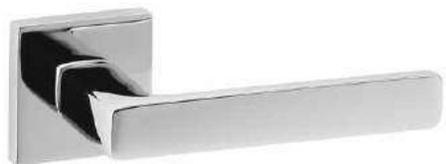

CR

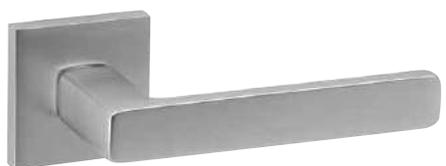

CS



PWIX



PWGT



\*Q 167



BK



WTM

Rose  
Roseta

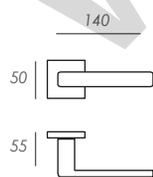

R8C

Narrow Rose  
Roseta Estrecha

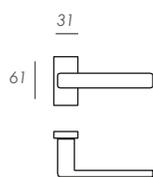

REC

Escutcheon  
Bocallave



R8CBB

R8CB

WC Set  
Condensa



R8CCD

Window Handle  
Grisán

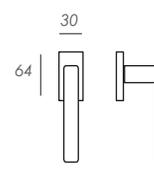

GC

Rectangular Backplate  
Placa Rectangular

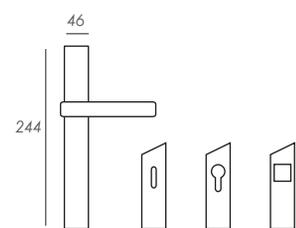

PC

PCBB

PCB

PCCD

# IPNOS 816

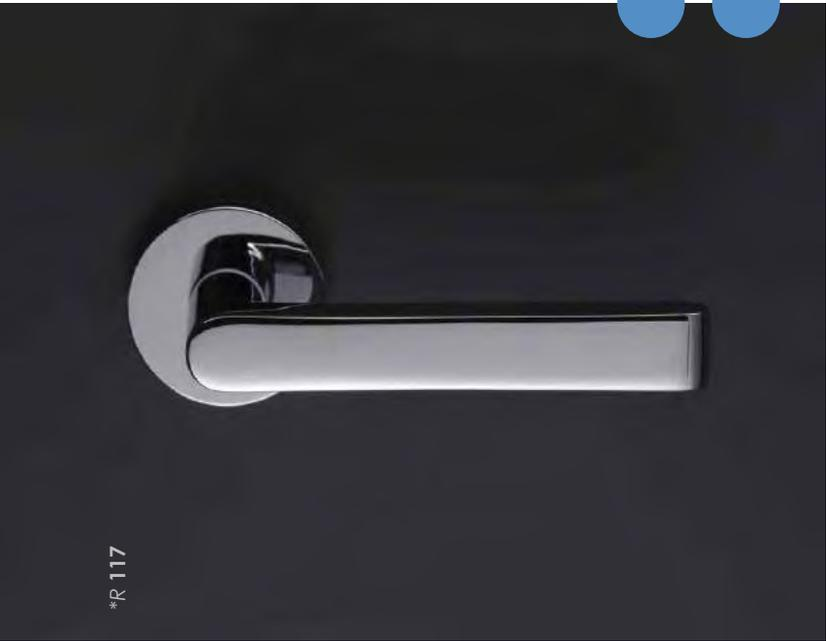

PWLP



PWLS

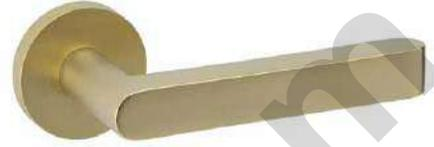

CR



CS



PWIX



PWGT



BK



WTM



Rose  
Roseta

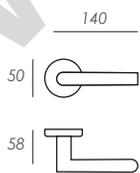

R8

Narrow Rose  
Roseta Estrecha

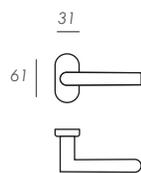

RE

Escutcheon  
Bocallave

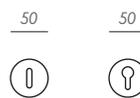

R8BB R8B

WC Set  
Condena



R8CD

Window Handle  
Grisán

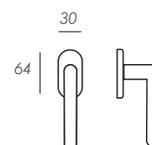

G

Oval Backplate  
Placa Oval

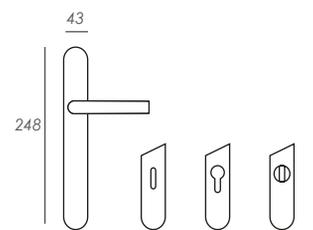

P PBB PB PCD





# ÁNGOLO 817

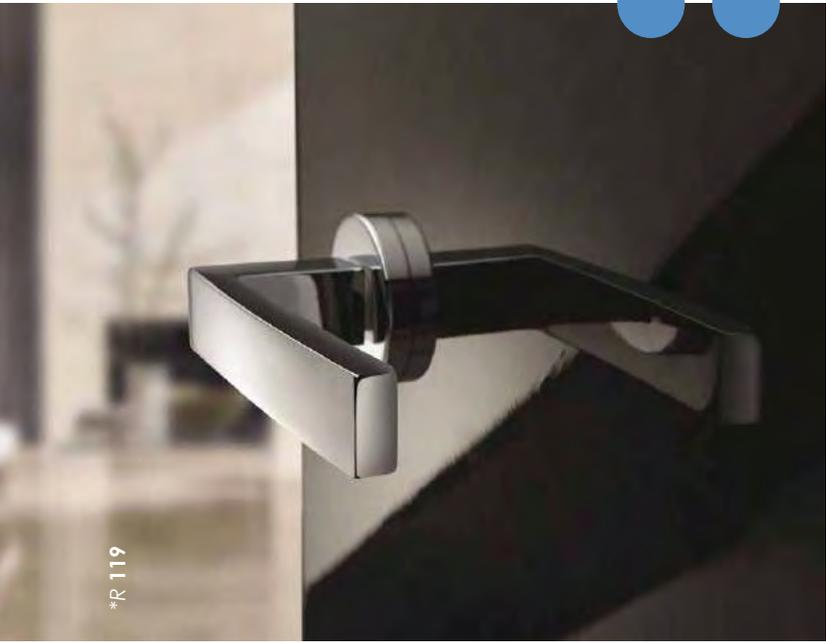

\*R 119

PWLP



PWLS

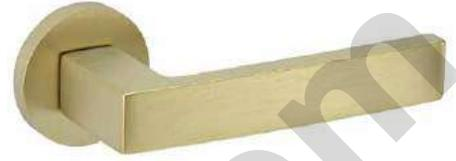

CR



CS



BK



WT



PWIX



PWGT



Rose  
Roseta

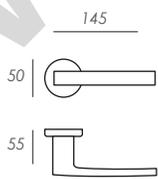

R8

Narrow Rose  
Roseta Estrecha

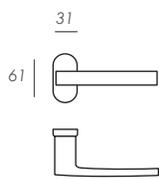

RE

Escutcheon  
Bocallave



R8BB

R8B

WC Set  
Condena



R8CD

Window Handle  
Grisán

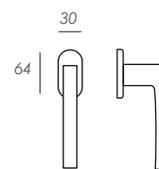

G

Oval Backplate  
Placa Oval

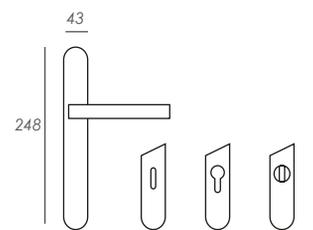

P

PBB

PB

PCD

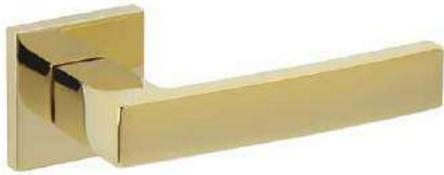

PWLP

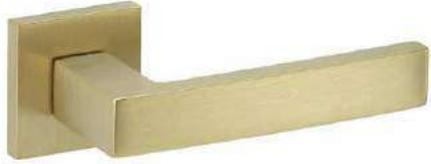

PWLS



CR



CS



PWIX



PWGT

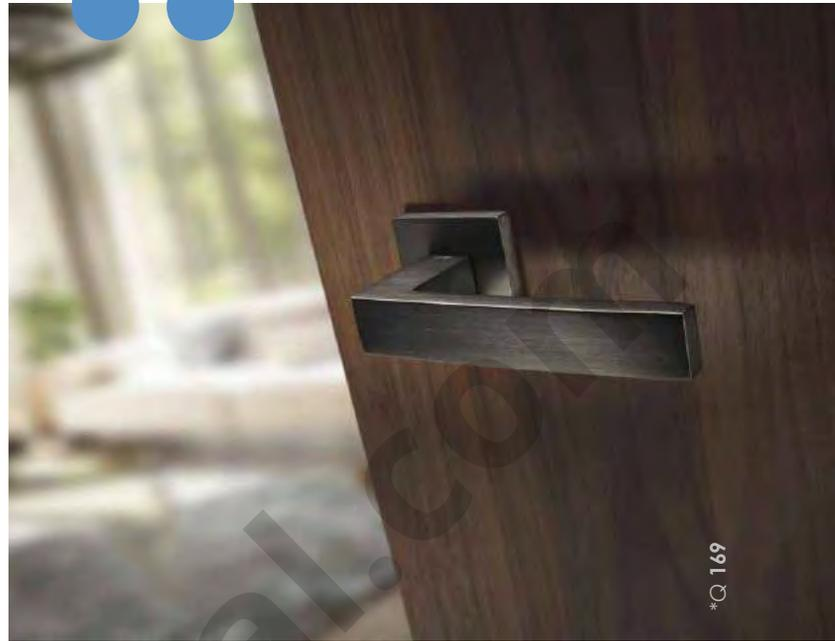

\*Q 169



BK



WT

Rose  
Roseta

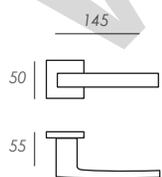

R8C

Narrow Rose  
Roseta Estrecha

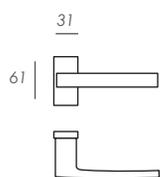

REC

Escutcheon  
Bocallave



R8CBB

R8CB

WC Set  
Condensa



R8CCD

Window Handle  
Grisán

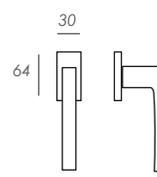

GC

Rectangular Backplate  
Placa Rectangular

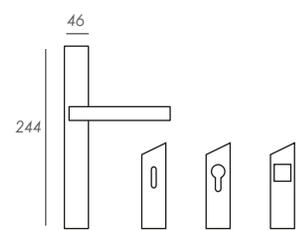

PC

PCBB

PCB

PCCD

BEL.LA 110m



BO CRAQ

BO MF

Pull Handle  
Manillón

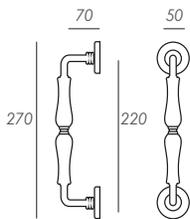

M



\*M 218

# QUADRO 127m



Pull Handle  
Manillón

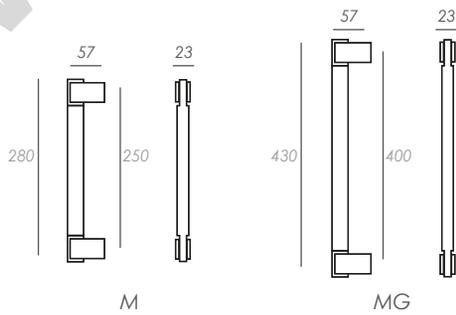

# PLANO 137m



CR

CR CS

CS

Pull Handle  
Manillón

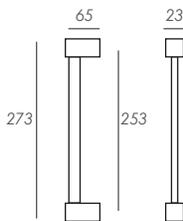

M



\*M 221



CR

CS

NS

BK

Pull Handle  
Manillón

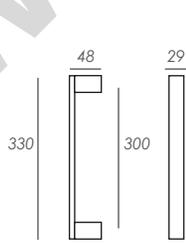

M30

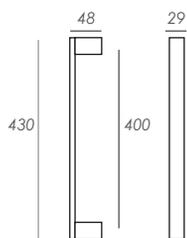

M40

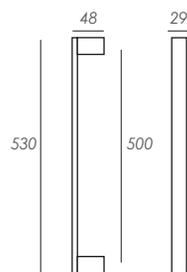

M50

# TORSO 235m



PWLP

PWLS

CR

CS

PWIX

Pull Handle  
Manillón

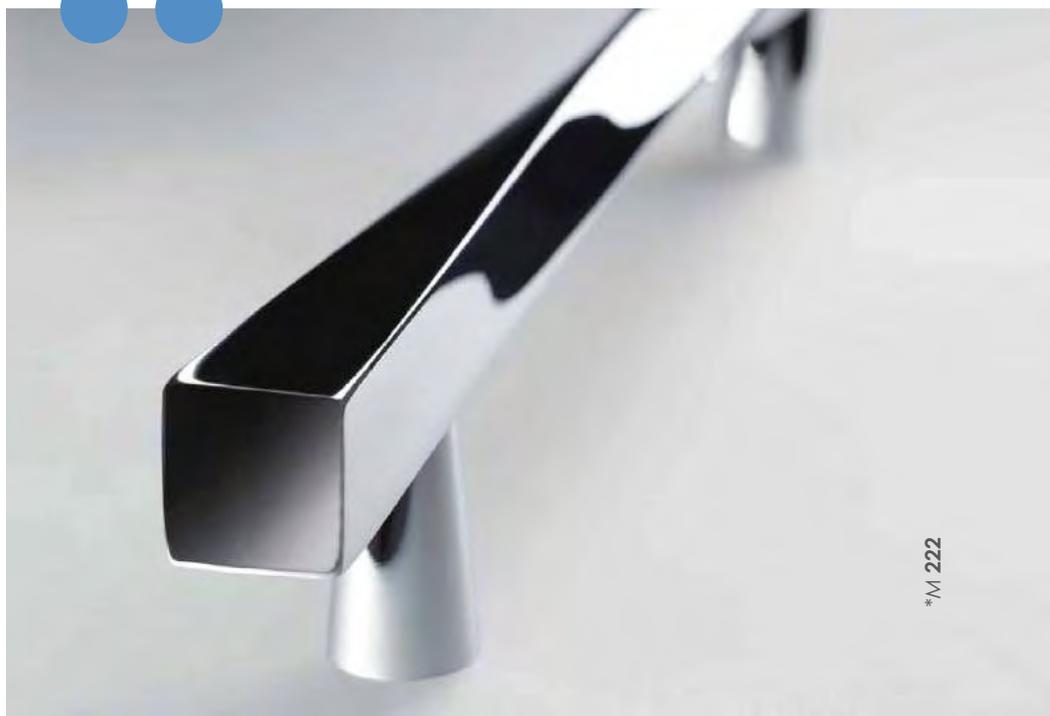
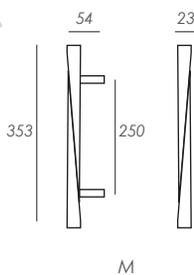



IBIZA 256m



\*M 223



PWGT

PWIX

PWLS

Pull Handle  
Manillón

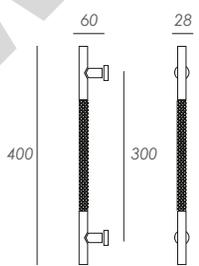

M30

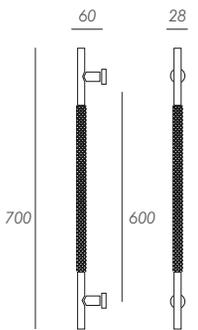

M60

# TROMBETTA 510m

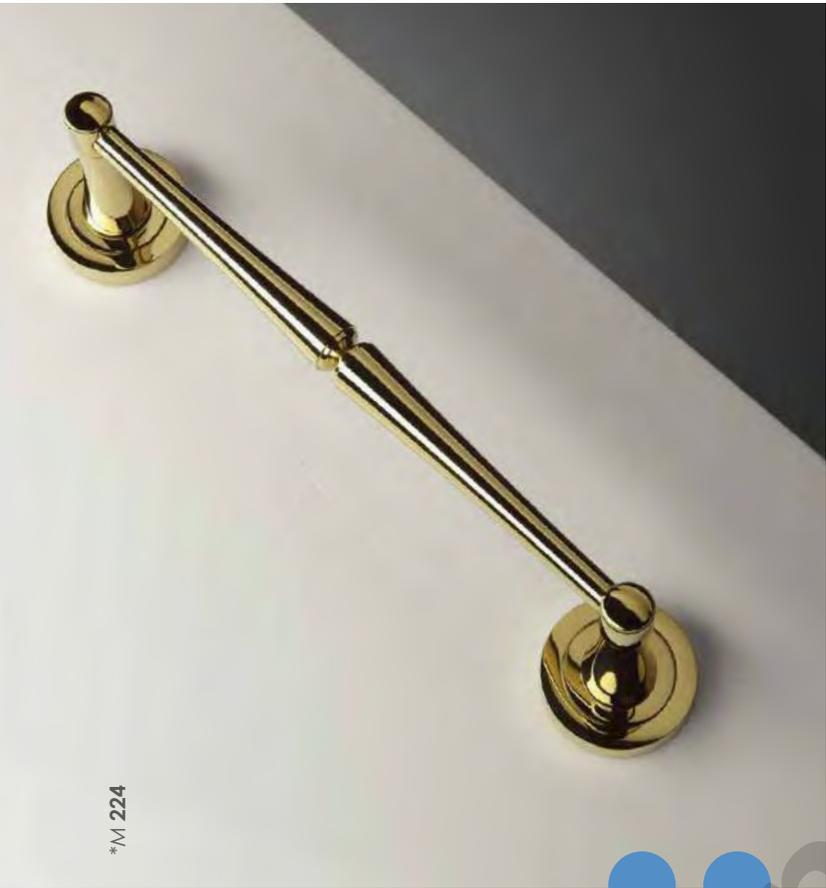

\*M 224



RV PWLP  
R3 PWLP

R3 PWNB  
RV PWNB

Pull Handle  
Manillón

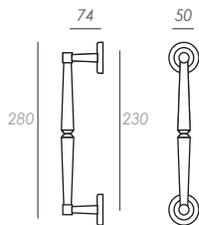

M

# MANEGA 520m



R3 PWLP  
RV PWLP

R3 PWNB  
RV PWNB

Pull Handle  
Manillón

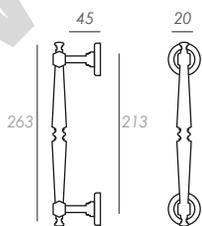

M

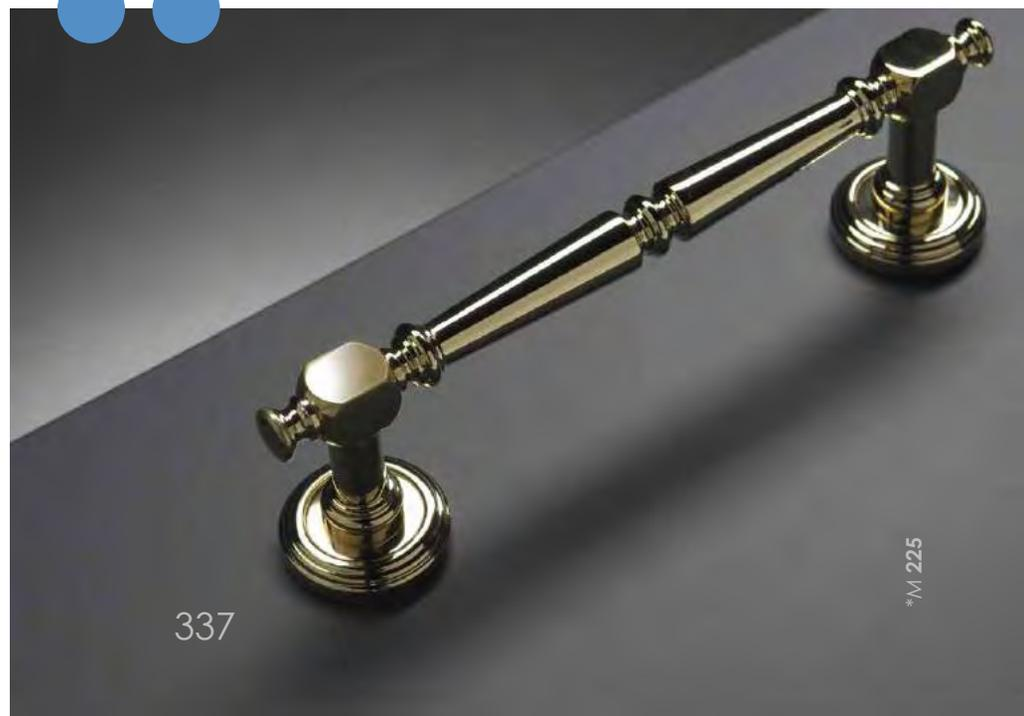

# OTTO 528m

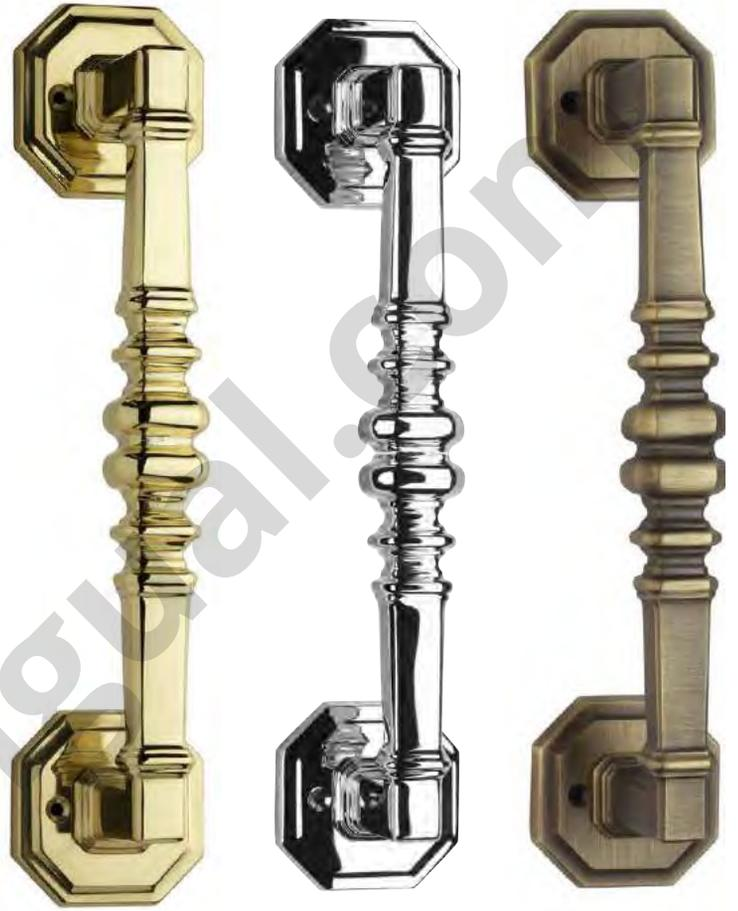

LP

CR

BO

Pull Handle  
Manillón

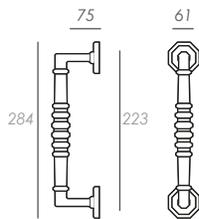

M

# PALLINE 533m



PWLP

PWNB

More finishes available in:  
Más acabados disponibles en:  
[groel.es](http://groel.es)

Pull Handle  
Manillón

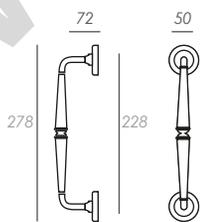

M

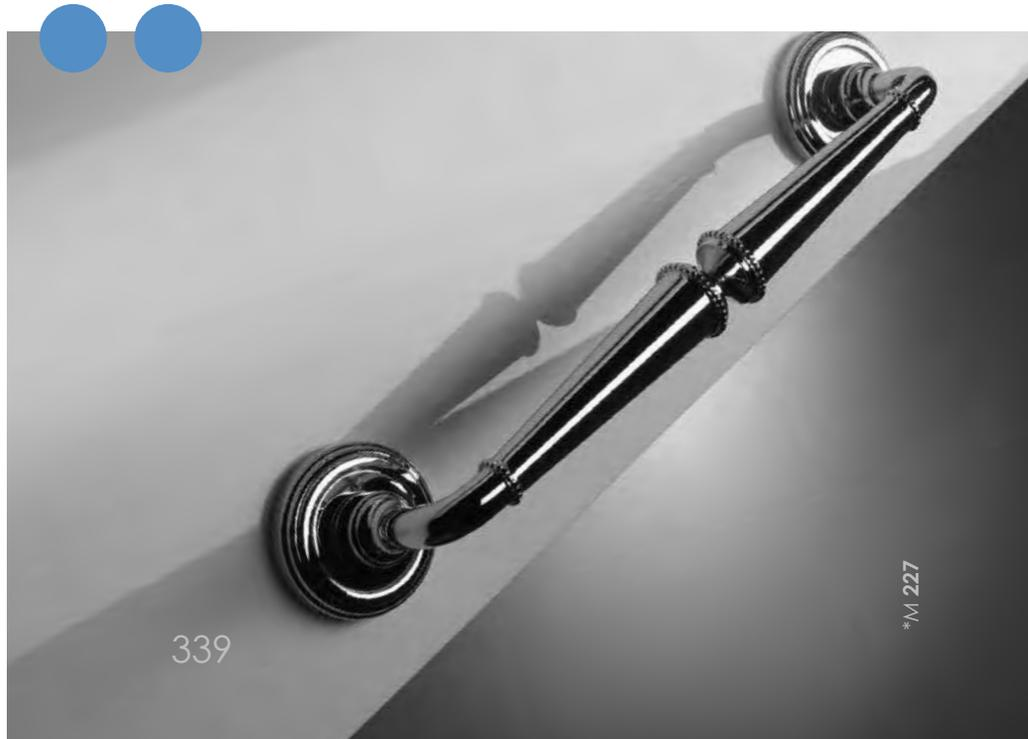

# VASILISA 540m



\*M 228

More finishes available in:  
Más acabados disponibles en:  
[groel.es](http://groel.es)



PWLP



PWNB

Pull Handle  
Manillón

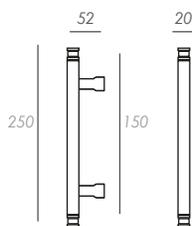

M

# ARTDÉCO 550m



PWLP

PWNB

Pull Handle  
Manillón

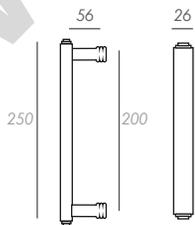

M

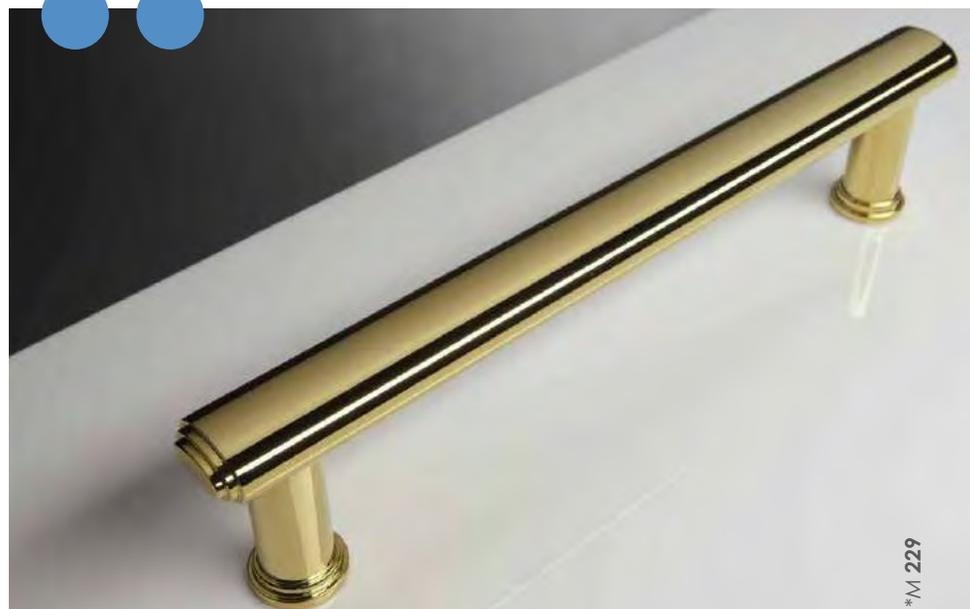

341

\*M 229

# NONNA 560m



\*M 231

More finishes available in:  
Más acabados disponibles en:  
[groel.es](http://groel.es)



PWLP



PWNB

Pull Handle  
Manillón

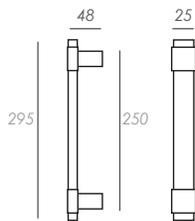

M



# MALIKA 570m



PWLP

PWNB

More finishes available in:  
Más acabados disponibles en:  
[groel.es](http://groel.es)

Pull Handle  
Manillón

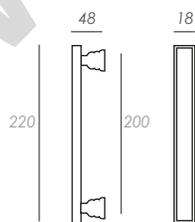

M

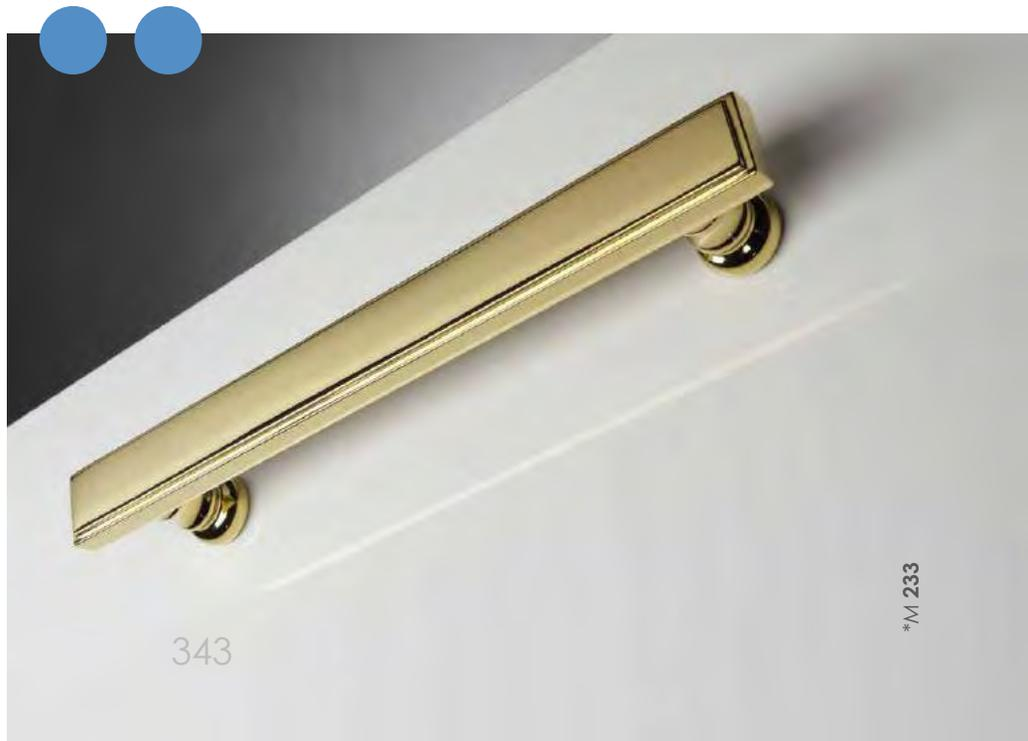

343

\*M 233

# TECNO 801m



\*M 234



LP

LS

CR

Pull Handle  
Manillón

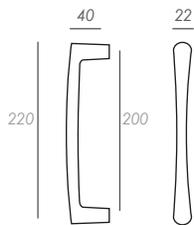

M



CS



NS



CF



BO



FU



MR

www.mechanical.com

# NUOVO 805m



\*M 236



LP

LS

CR

Pull Handle  
Manillón

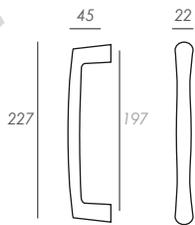

M



CS



NS



AQ



BO



FU



HI

# KILTO 809m



LP



OB



AQ



MR



HI



Pull Handle  
Manillón

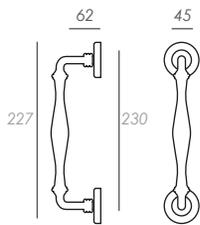

M

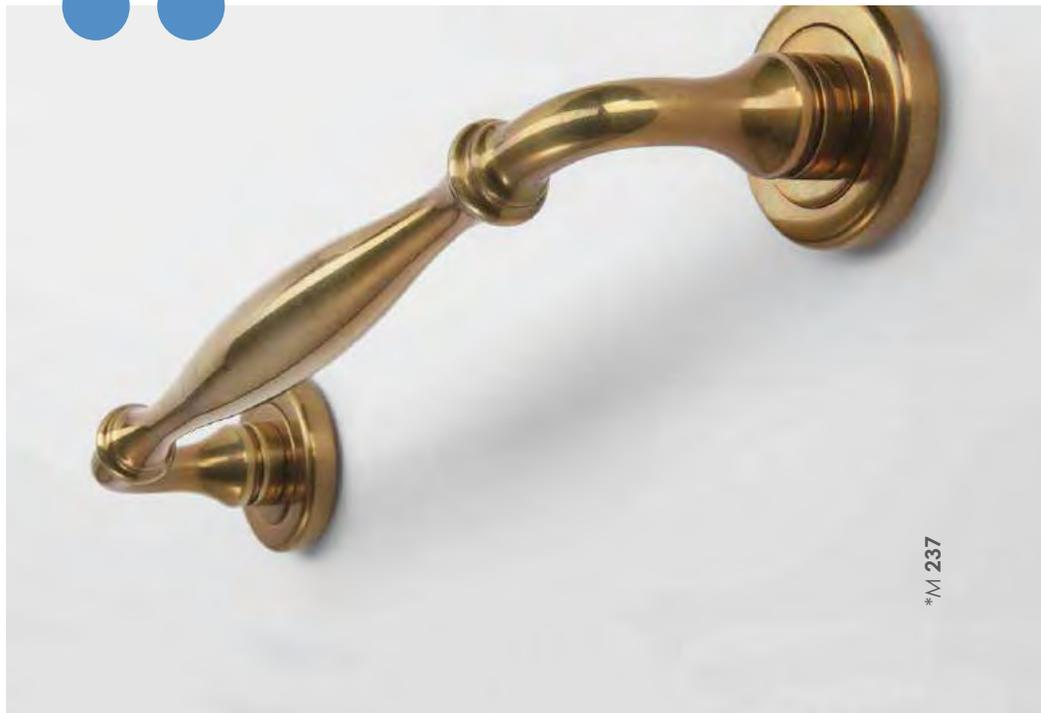



AQ



BO



FU



HI



LP LS

Pull Handle  
Manillón

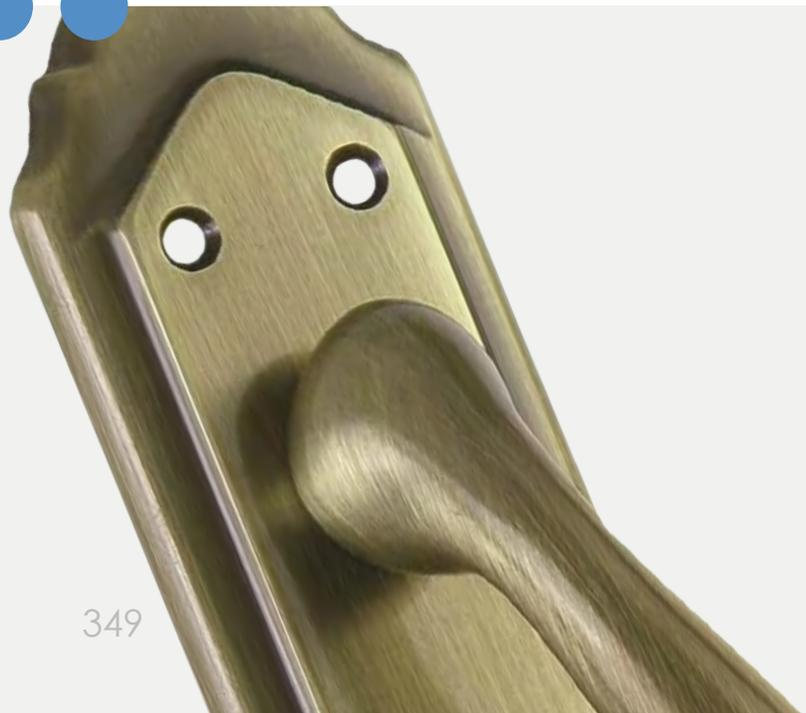
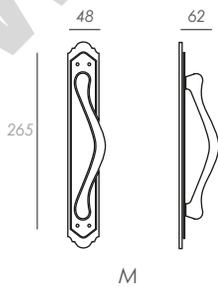

# ÁNGOLO 817m



LP

LS

CR

CS

NS

Pull Handle  
Manillón

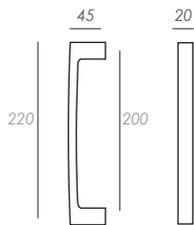

M

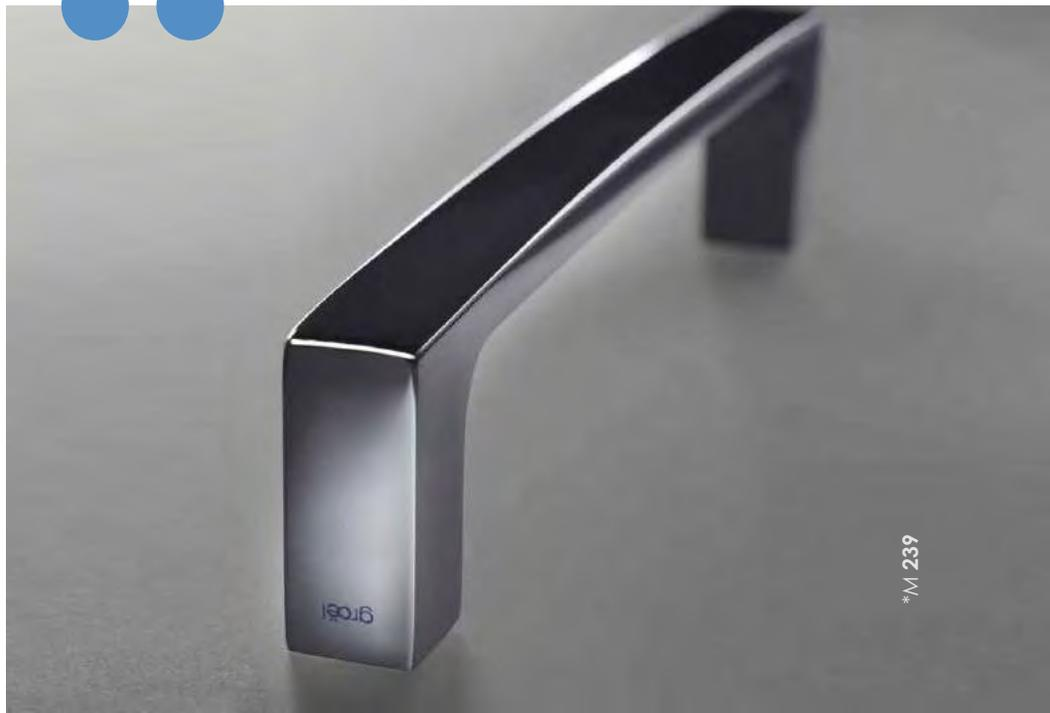





PWLS

PWLP

PWIX

PWGT

BK

WT

www.menargual.com

LOG.GIC 827m



LP

LS

CR

CS

NS

Pull Handle  
Manillón

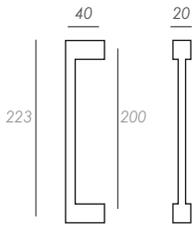

M



\*M 240



PWLP



PWLS



PWIX



PWGT



BK



WT

www.mengsual.com

# LIFTER 400



CS



CS

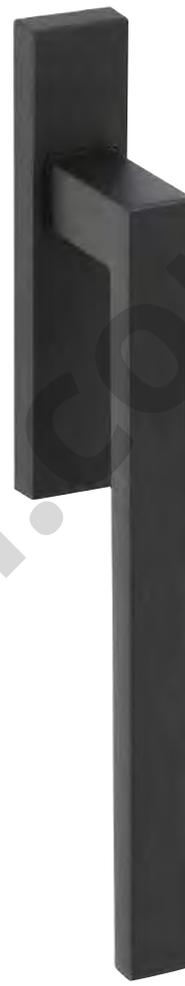

BK



Lifter Pull Handle  
Manillón Elevador

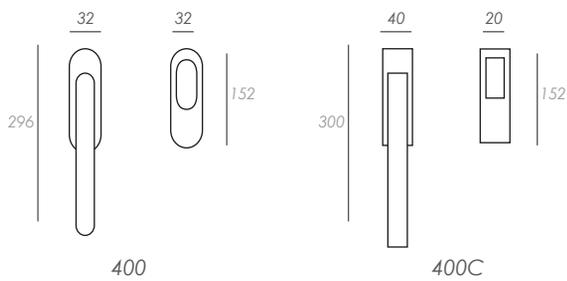



\*P 245



LP



LS



CR



CS



NS

Door Knob  
Pomo

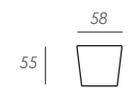

P

# CUADRO 317



LP



PWLS



CR



CS



NS



PWIX



BK

Door Knob  
Pomo

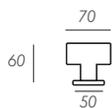

P



# DADO 327



\*P 247



LP



CR



CS



MS



PWIX

Door Knob  
Pomo

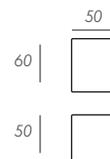

P

# BIG 335



CR



CS



NS



PWIX

Door Knob  
Pomo

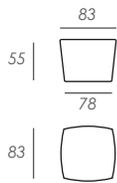

P





WIDE 357

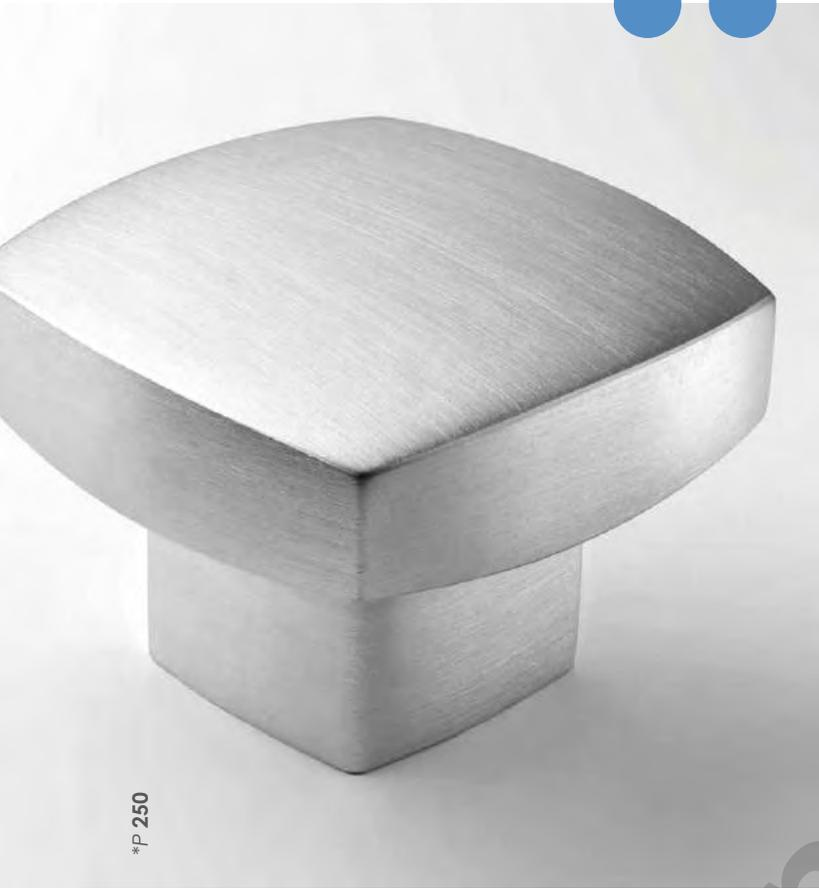

LP



PWLS



CR



CS



NS



PWIX

Door Knob  
Pomo

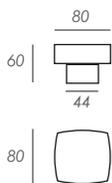

P

# DADO 318



LP



LS



CR



CS



NS



CF

Door Stop  
Type

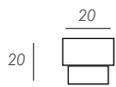

T



CUBE 319



\*T 25T



LP



LS



CR



CS



NS



CF



BK



WT



HI

Door Stop  
Top

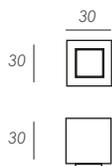

T

# INSTALLATION INSTRUCTIONS

## INSTRUCCIONES DE MONTAJE

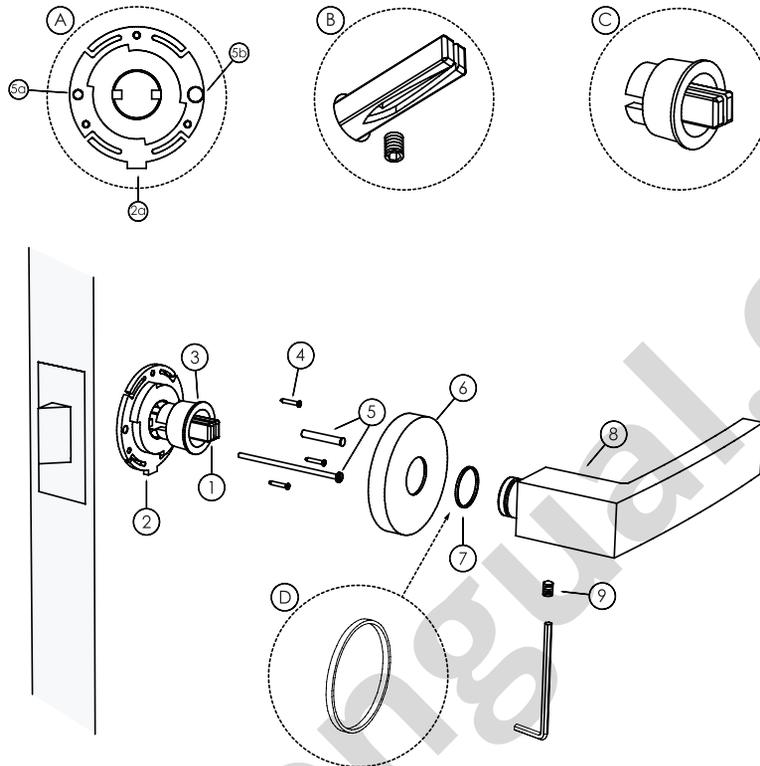

1. Insert the spindle (1) in the lock. Follow position shown on fig.B relative to the allen screw (9).
2. Place the inner ring (2) in the right position fig.A. The flap (2a) must point to the ground.
3. Use the plastic piece (3) to centre the inner ring (fig.C).
4. Screw the inner ring with the supplied screws (4).
5. (Optional) Use the through bolt screws (5) as shown in fig.A. Hole (5a) for male and (5b) for female.
6. Remove the plastic piece used to centre the inner rose.
7. Adjust the rose (6). The notch (6a) must be inserted on the flap (2a).
8. Insert the plastic ring (7) -fig.D- in the door handle neck to avoid any scratch when operating.
9. Place the door handle (8) and fix it to the spindle(fig.B) with the allen screw (9).

1. Introducir el cuadradillo (1) en la cerradura según posición de la fig.B respecto al tornillo allen (9).
2. Colocar el interno (2) en la posición de la fig.A. La muesca (2a) debe apuntar al suelo.
3. Usar la pieza plástica (3) para centrar el interno (fig.C).
4. Atornillar el interno con los tornillos suministrados (4).
5. (Opcional) Colocar los tornillos pasantes (5) según figura fig.A. Agujero (5a) macho y (5b) hembra.
6. Quitar la pieza plástica usada para centrar la roseta.
7. Colocar la roseta (6). Debe encajar el rebaje (6a) con la pestaña (2a).
8. Insertar la arandela de plástico (7) -fig.D- en el cuello de la manilla para evitar roces al accionar.
9. Colocar la manilla (8) y fijarla al eje (fig.B) con el tornillo allen (9)

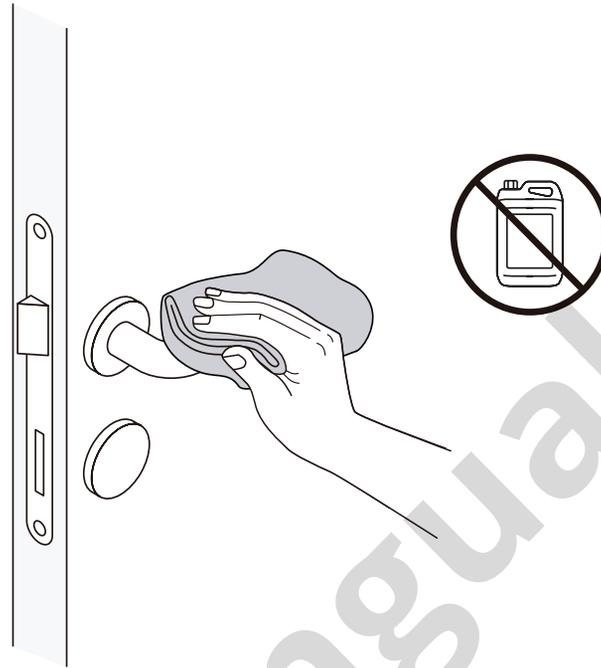

Clean with a dry cloth.  
Do not use brass cleaner  
as it might affect the protective coating.

Note: Handles vary by style  
but maintenance is the same for all of them.

*Limpiar con un paño seco.  
No usar productos químicos o abrasivos,  
pueden dañar la capa protectora.*

*Nota: Los modelos pueden variar  
pero no así el mantenimiento.*





THANK YOU  
GRACIAS

[www.mengual.com](http://www.mengual.com)



● ● groel.es

www.mensual.com